

DEPARTMENT OF THE ARMY TECHNICAL MANUAL

OPERATOR, ORGANIZATIONAL, DS, GS, AND
DEPOT MAINTENANCE MANUAL INCLUDING
REPAIR PARTS AND SPECIAL TOOL LISTS

WIND MEASURING SET AN/PMQ-3A
(NSN 6660-515-4339)

This copy is a reprint which includes current
pages from Changes 1 through 3.

HEADQUARTERS, DEPARTMENT OF THE ARMY
19 JULY 1968

CHANGE

HEADQUARTERS

DEPARTMENT OF THE ARMY

No. 3

WASHINGTON, DC, 15 October 1984

Operator's Organizational, Direct Support, General Support, and Depot Maintenance Manual

**WIND MEASURING SET AN/PMQ-3A
(NSN 6660-00-515-4339)**

TM 11-6660-232-15, 19 July 1968 is changed as follows:

1. New or changed material is indicated by a vertical bar in the margin. New or revised illustrations are indicated by a vertical bar in front of the figure caption.
2. Remove old pages and insert new pages as follows:

Remove page s

i

1-1 and 1-2

4-1 and 4-2

6-1 and 6-2

8-1

A-1

B-1 and B-2

Insert pages

i (ii blank)

1-1 and 1-2

4-1 and 4-2

6-1 and 6-2

8-1/(8-2 blank)

A-1/(A-2 blank)

B-1 through B-3/(B-4 blank)

3. File this change sheet in front of the publication.

By Order of the Secretary of the Army:

Official:

JOHN A. WICKHAM JR.
General, United States Army
Chief of Staff

ROBERT M. JOYCE
Major General United States Army
The Adjutant General

DISTRIBUTION

To be distributed in accordance with DA Form 12-25C, Organizational Maintenance requirements for METEOROLOGY.

TECHNICAL MANUAL

No. 11-6660-232-15

HEADQUARTERS
DEPARTMENT OF THE ARMY
WASHINGTON, DC, 19 July 1968**Operator, Organizational, Direct Support, General Support, and Depot Maintenance Manual****WIND MEASURING SET AN/PMQ-3A
(NSN 6660-00-515-4339)**

			Paragraph	Page
CHAPTER	1.	INTRODUCTION		
SECTION	I.	GENERAL	1-1 1-3.4	1-1
	II.	Description and data.....	1-4 1-9	1-1
CHAPTER	2.	INSTALLATION AND OPERATING INSTRUCTIONS		
SECTION	I.	Service upon receipt of equipment.....	2-1 2-5	2-1
	II.	Operating instructions.....	2-6 2-7	2-4
	III.	Operation under unusual conditions.....	2-8 2-10	2-5
CHAPTER	3.	OPERATOR'S MAINTENANCE INSTRUCTIONS.....	3-1 3-8	3-1
	4.	ORGANIZATIONAL MAINTENANCE		
SECTION	I.	Preventive maintenance	4-1 4-8	4-1
	II.	Troubleshooting.....	4-9 4-12	4-3
	III.	Circuit functions.....	4-13 4-15	4-4
CHAPTER	5.	DIRECT SUPPORT MAINTENANCE		
SECTION	I.	General.....	5-1 5-2	5-1
	II.	Direct support troubleshooting and repair procedures	5-3 5-5	5-1
CHAPTER	6.	GENERAL SUPPORT MAINTENANCE.....	6-1 6-5	6-1
	7.	DEPOT MAINTENANCE	7-1 7-5	7-1
CHAPTER	8.	SHIPMENT AND LIMITED STORAGE		
		Shipment and limited storage	8-1 8-2	8-1
APPENDIX	A.	REFERENCES		A-1
	B.	COMPONENTS OF END ITEM (COEIL)		
SECTION	I.	Introduction		B-1
	II.	Integrated components of end item		B-2
	III.	Basic issue items.....		B-3
APPENDIX	C.	MAINTENANCE ALLOCATION		
SECTION	I.	Introduction.....		C-1
	II.	Maintenance allocation chart.....		C-3
	III.	Tool, and tent equipment requirements.....		C-4
	IV.	Remarks		C-5
APPENDIX	D.	ORGANIZATIONAL. DS, GS, AND DEPOT REPAIR PARTS		
SECTION	I.	Introduction		D-1
	II.	Repair parts for organizational maintenance.....		D-4
	III.	Repair parts for direct support, general support, and depot maintenance		D-5
	IV.	Index-federal stock number cross-reference to index number		D-12
	V.	Index-figure and Item number cross-reference to index number		D-14
	VI.	Index-reference designation cross-reference to index number.....		D-15

*This manual supersedes TM 11-8660-232-15, 10 January 1962. Including all changes TM 11 6660-232-20P, 29 January 1964; and TM 11-6660-35P, 2 March 1964.

Change 3 i/(ii blank)

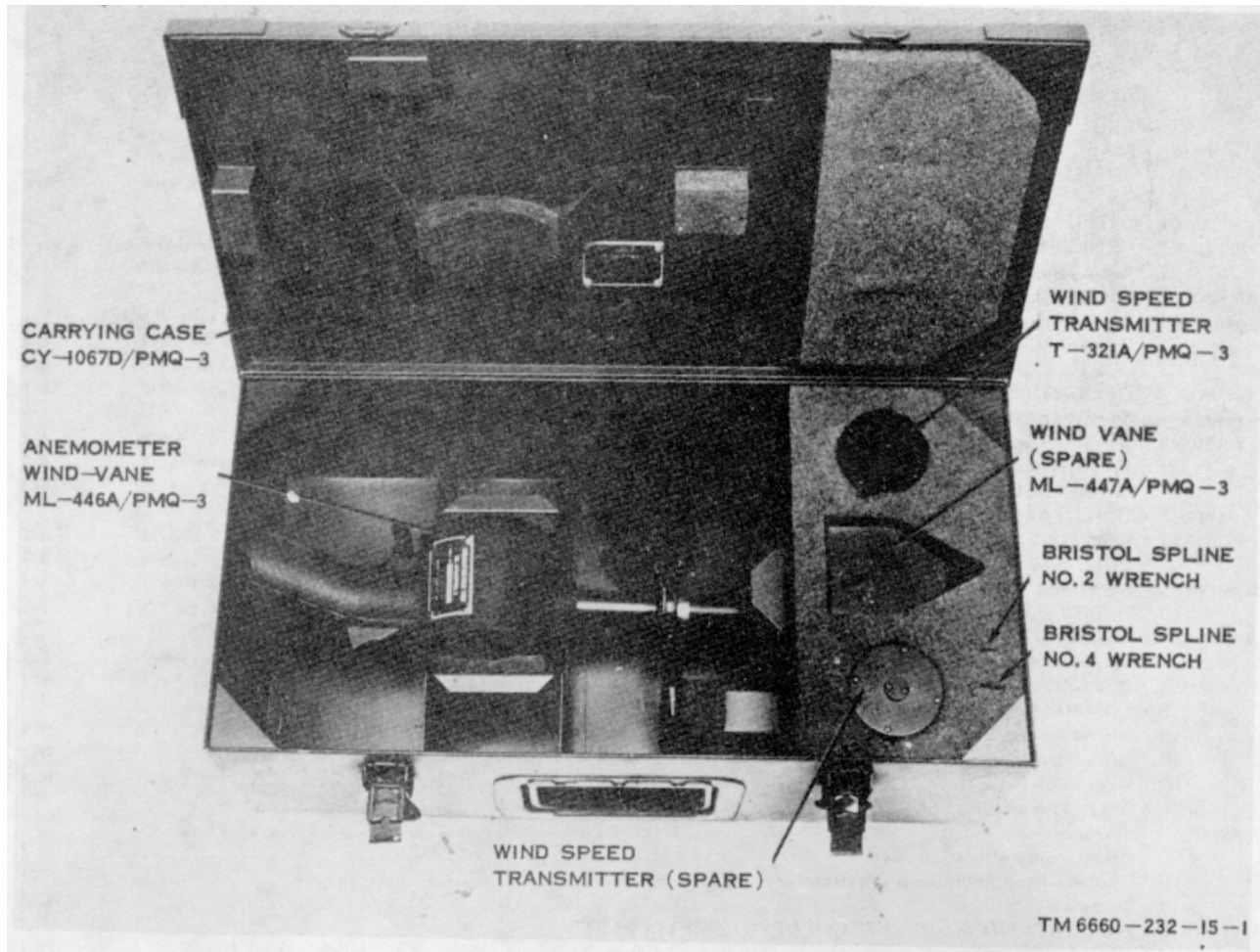

Figure 1-1. Wind Measuring Set AN/PMQ-3, with components.

Change 2 1-0

CHAPTER 1 INTRODUCTION

Section I. GENERAL

1-1. Scope

a. This manual describes Wind Measuring Set AN/PMQ-3A (fig. 1-1) and provides instructions for operation and installation, including operator, organizational, direct support, general support, and depot maintenance. Instructions are provided for installation, operation, preventive maintenance, lubrication, and replacement of parts. Circuit functioning is included at the organizational category, also included are instructions for troubleshooting, testing, adjustment, alignment, and repair of the equipment.

b. Appendix A contains a list of current references, including supply catalogs, technical manuals, and other publications applicable to the equipment.

c. Appendix B contains the components of end item list (COEIL) and basic issue items list (BII).

d. Appendix C contains the maintenance allocation chart.

e. Appendix D contains the repair parts and special tools lists.

1-2. Consolidated Index of Army Publications and Blank Forms

Refer to the latest issue of DA Pam 310-1 to determine whether there are new editions, changes, or additional publications pertaining to the equipment.

1-3. Maintenance Forms, Records, and Reports

a. *Reports of Maintenance and Unsatisfactory Equipment.* Department of the Army forms and procedures used for equipment maintenance will be those prescribed by DA Pam 738-750 as contained in Maintenance Management Update.

b. *Report of Packaging and Handling Deficiencies.* Fill out and forward SF 364 (Report of Discrepancy ROD) as prescribed in AR 735-11-2/DLAR 4140.55/ NAVMATINST 4355.73A/AFR 400-54, MCO 4430.3F.

c. *Discrepancy in Shipment Report e DISREP (SF 161).* Fill out and forward Discrepancy in Shipment Report (DISREP) (SF 361) as prescribed in AR 55-38/ NAVSUPINST 4610.33 C/,AFR 75-18, MCO P4610.19D/ DLAR 4500.15.

1-3.1. Reporting Errors and Recommending Improvements

you can help improve this manual. If you find any mistake or if you know of a way to improve the procedures, please let us know. Mail your letter or DA Form 2028 (Recommended Changes to Publications and Blank Forms) direct to: Commander, US Army Communications-Electronics Command and Fort Monmouth, ATTN.: DRSEL-ME-MP, Fort Monmouth, New Jersey 07703-5007. In either case, a reply will be furnished direct to you.

1-3.2 Reporting Equipment Improvement Recommendations (EIR)

If your Wind Measuring Set AN/PMQ-3A needs improvement, let us know. Send us an EIR. You, the user, are the only one who can tell us what you don't like about your equipment. Let us know why you don't like the design. Put it on an SF 368 (Quality Deficiency Report). Mail it to Commander, US Army Communications-Electronics Command and Fort Monmouth, ATTN.: DRSEL-ME-MP, Fort Monmouth, New Jersey 07703-5007. We'll send you a reply.

1-3.3. Hand Receipt

This manual has a companion document with a TM number followed by "-HR" (which stands for Hand Receipt). The TM 11.6660-232-15-HR consists of preprinted hand receipts (DA Form 2062) that list end item related equipment (i.e., COEI, BII, and AAL) you must account for. As an aid to property accountability, additional -HR manuals may be requisitioned from the LS Army Adjutant General Publications Center, Baltimore, Md., in accordance with the procedures in Chapter 3, AR 310-2, and DA Pam 310-10-2.

1-3.4. Destruction of Army Electronics Materiel

Destruction of Army electronics materiel to prevent enemy use shall be in accordance with TM 750-244-2.

Section II. DESCRIPTION AND DATA

1-4. Purpose and Use

a. Wind Measuring Set AN/PMQ-3A is a complete, portable wind measuring system which gives visual indications of wind direction through 3600 and windspeed readings from 0 to 60 knots. The measuring instrument is designed to be hand-held during operation.

b. The equipment is used by field units when making visual observations of the atmosphere in support of artillery units or meteorological forecasts. The information obtained by these observations are used to prepare wind data for atmospheric effects on artillery firings and information for surface observations in support of forecasts for field operations.

1-5. Technical Characteristics

a. *General.*

Windspeed60 knots maximum.
 Wind direction.....0-3600 in azimuth.

b. *Transmitter.*

Turbine generatorRotor generator with voltage output proportional to windspeed.
 Generator output4.46 vac ±0.06 at rotor speed of 120 Hz (40 knots).

c. *Indicator.*

Windspeed:
 Inner scale.....0-15 knots.
 Outer scale.....0-60 knots.
 Range toggle switch.....0-60 scale.
 normal.
 Range toggle switch.....0-15 scale.
 operated.
 Accuracy.....±1/2 knot from 0-7;
 ±1 knot from 10-40,
 ±2 knots from 41 to 60 knots.
 Wind direction:
 Trigger switch engaged.....Free movement from 0-360°.
 Trigger switch released.....Locking brake for wind vane pointer direction reading.
 Accuracy.....±2° in a 5-knot wind.

1-6. Components and Dimensions

(fig. 1-1)

Dimensions of Major Components.

Qty	Item	Dimensions (in.)			Unit wt (lb)
		Height	Length	Width	
1	Case, Carrying CY-1067D/PMQ-3.	7 3/4	22	11	15
1	Anemometer, Wind Vane ML-446A/PMQ-3	15	15	3 1/2	3 1/2
2	Wind Speed Transmitter T-321A, PMQ-3.	5 3/4	5 3/4	25/8	1 1/2
2	Wind Vane ML-447A/PMQ-3.	2 3/4	3 3/4	5 1/2	

1-6.1. Items Comprising Operable Wind Measuring Set AN/PMQ3A

FSN	QTY	Nomenclature, part No., and mfr code	Fig. No.
6360-515-4339		Wind Measuring Set AN/PMQ-3A; AN/PMQ-3A; SMD-367358, 80063, Consisting of:	1-1
6660-515-4341	1	Anemometer Wind Vane ML-446A/PMQ3	1-3
6660-323-2262	1	Wind Vane MIL--447A/PMQ3	2-3
6660-515-4342	1	Wind Speed Transmitter T-312A/PMQ-3	2-2
<p style="text-align: center;">NOTE</p> <p>The part number is followed by the applicable 5-digit Federal supply code for manufacturers (FSCM) identified in SB 708-42 and used to identify manufacturer, distributor, or Government agency, etc.</p>			

Change 1 1-2.1

1-7. Common Names

A list of nomenclature assignments for the components of Wind Measuring Set AN/PMQ3A is given below. A common name is indicated after each item.

<i>Nomenclature</i>	<i>Common name</i>
Wind Measuring Set AN/PMQ-3A.	Wind measuring set
Transmitter, Wind Speed T-321A/PMQ-3.	Transmitter
Anemometer, Wind Vane ML-446A/PMQ3.	Anemometer wind vane
Wind Vane ML-447A/PMQ-3	Wind vane
Case, Carrying CY-1067D/	Carrying case PMQ-S.

1-8. Description of Wind Measuring Set AN / PMQ-3A

(fig. 1-1)

a. The wind measuring set has four major components, Wind Speed Transmitter T321A/ PMQ-3 (fig. 2-2), Anemometer, Wind Vane ML-446A/PMQ-3 (fig. 1-3), Wind Vane ML447A/PMQ-3A (fig. 2-3) and Carrying Case CY-1067D/PMQ-3 (fig. 1-1).

b. The windspeed section consists of the transmitter, windspeed indicator (voltmeter), and a range selector trigger. The wind direction section consists of a wind vane, graduated direction dial, vane lock trigger mechanism, and a direction sight.

1-9. Description of Components

a. *Wind Speed Transmitter T-321A/PMQ3* (fig. 2-2). The windspeed transmitter consists

Change 1 1-2.2

of an alternating current (ac) generator that is enclosed in a waterproof cover, driven by a three-bladed cylindrical turbine enclosed in a cage. The transmitter can be removed as a unit from the vertical extension tube (fig. 2-3).

b. Windspeed Indicator (fig. 1-3). The windspeed indicator is a voltmeter calibrated to indicate the windspeed in two ranges (from 0 to 15 and from 0 to 60 knots) on a 23/8-inch dial. The 0- to 15-knot scale is graduated in 5-knot increments. The 0- to 60-knot scale is graduated and marked in 10-knot increments. Numerals, major graduations, and the pointer are luminous painted. The indicator is removable as a unit from the housing. A range selector switch mechanism is provided for selection of speed range.

c. Range Selector Mechanism. The range selector mechanism consists of a switch (fig. 1-3) and a trigger (fig. 5-1). When the switch is closed (by pressing the range setting trigger), the low range is used. The switch and trigger mechanism is combined with the vane locking trigger mechanism to form an assembly which can be removed as a unit from the housing after the rear cover is removed.

d. Direction Vane Assembly (fig 1-3). The direction vane assembly consists of a wind direction vane, a mounting hub, and a nose vane (vane balanced weights). The direction vane assembly is mounted on the vertical tube of the housing, rotating on a ball bearing about a fixed direction dial (fig. 5-1). The mounting hubs of the direction dial and vane serve as races for the balls of the bearings. A lock trigger mechanism enables the

vane to be manually locked in position. The vane nose, which is also a balanced weight, may be screwed into or out of the hub until the desired balance is obtained. The nose is locked in position by a jamnut.

e. Direction Dial (fig. 5-1). The periphery of the 4-inch direction dial is graduated every degree and numbered every 10°. A hub is provided in the center of the dial to mount the dial on the vertical extension tube of the housing.

f. Wind Vane ML-447A/PMQ-3 (fig. 2-3). The wind vane is a twin rudder type. An index pointer is mounted on the main center support to indicate wind direction on the graduated direction dial. The vane tail assembly is attached to the mounting hub by two screws.

g. Vane Lock Trigger Mechanism (fig. 5-1). The vane lock trigger mechanism consists of a vane brake ring (fig. 1-3) and a vane lock trigger (fig. 4-1) connected by an internal push rod. The mechanism is spring-loaded so the brake is normally held against the mounting hub of the wind direction vane to protect the vane assembly from turning.

Depressing the trigger releases the trigger, and the direction van rotates freely.

h. Direction Sight (fig. 1-3). A direction sight, coated with luminous paint for operation in darkness, is attached to the underside of the housing. This sight enables the operator to align the "0" of the direction dial to a fixed point or object.

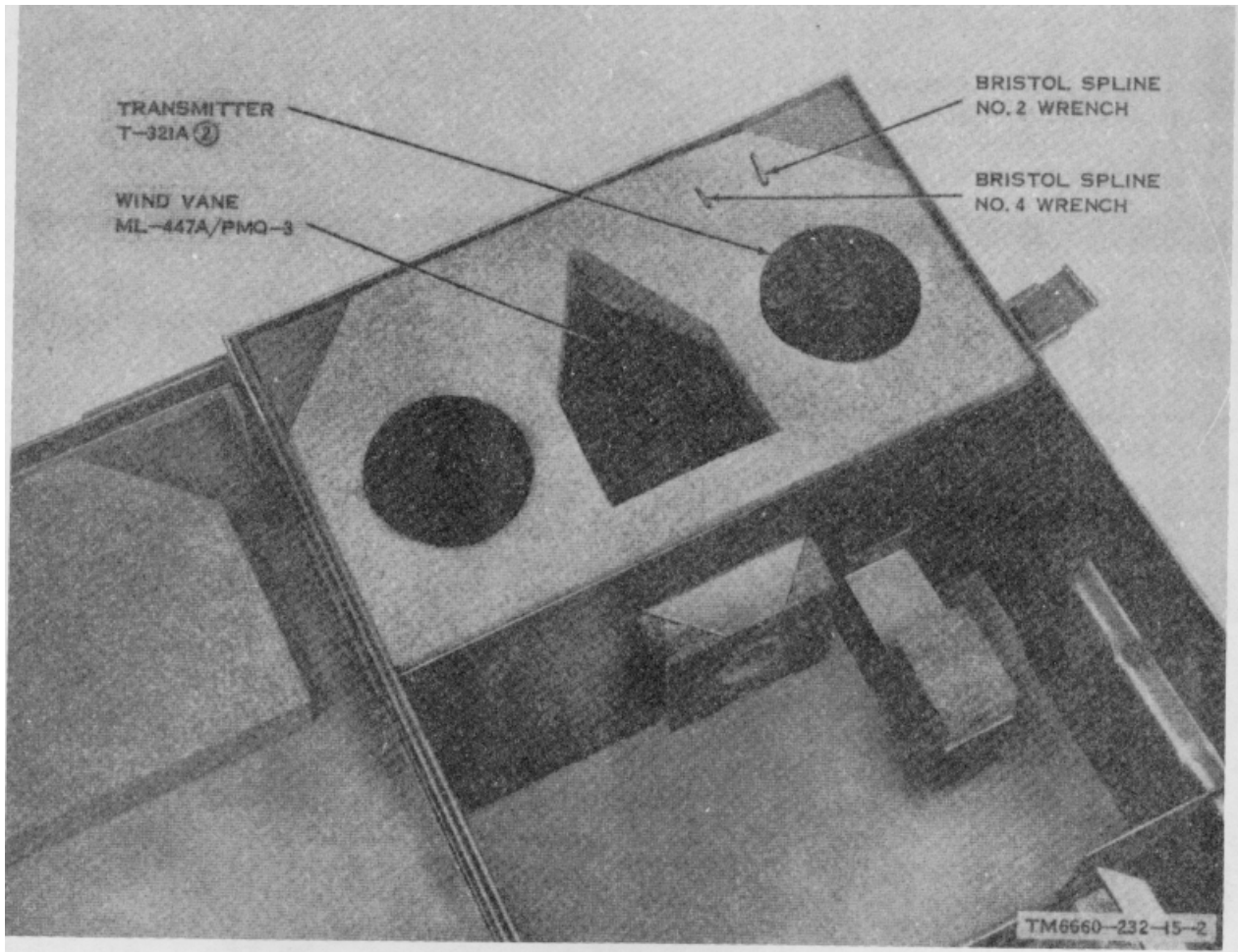

Figure 1-2. Carrying Case CY-1067D./PMQ-3 with spares.

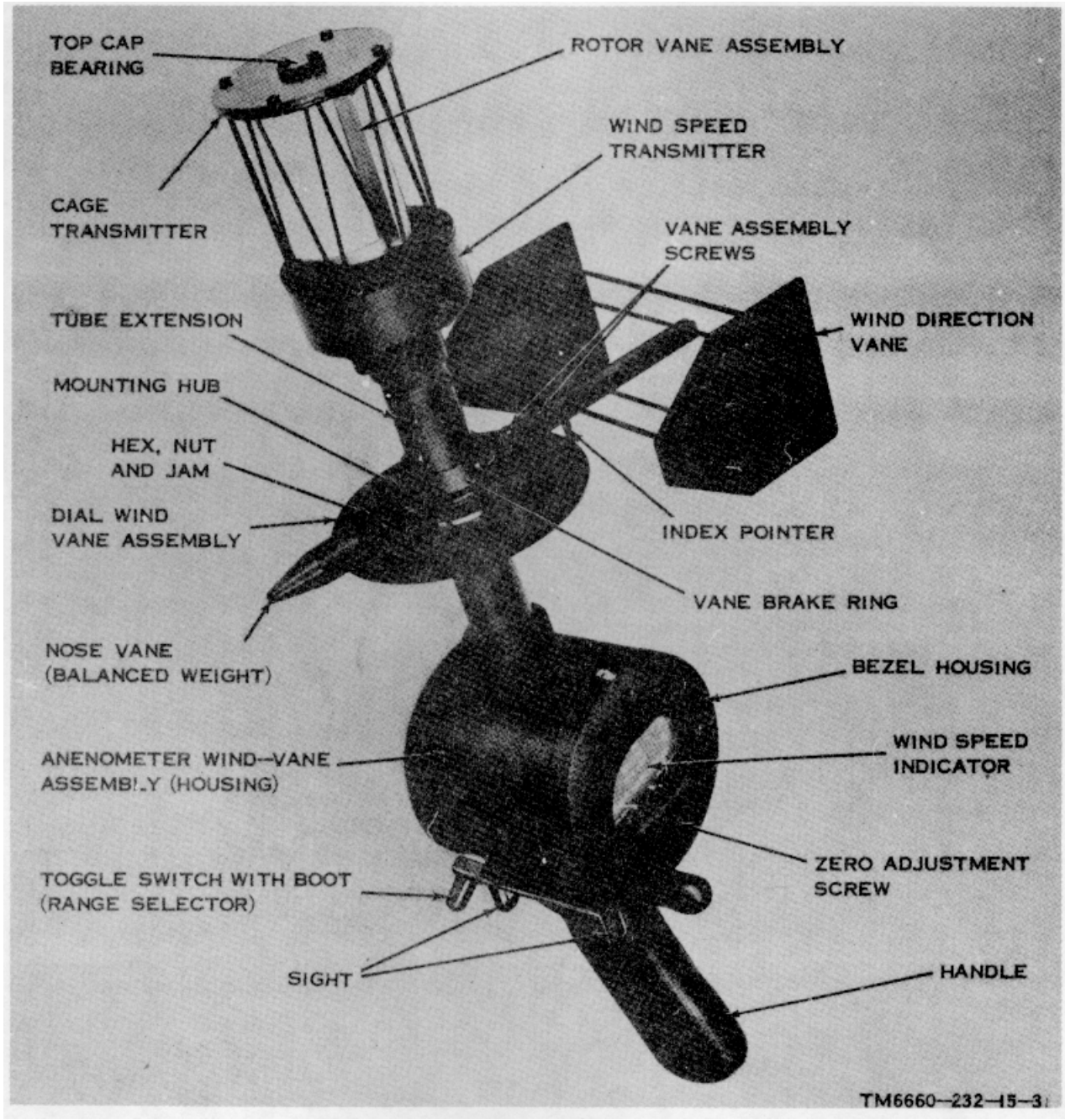

Figure 1-3. Anemometer, Wind Vane ML-446A/PMQ-3 assembled.

CHAPTER 2 INSTALLATION AND OPERATING INSTRUCTIONS

Section I. SERVICE UPON RECEIPT OF EQUIPMENT

2-1. Unpacking

(fig. 2-1)

a. Packaging Data. Wind Measuring Set AN/PMQ-3A is shipped to the using organization in a fiberboard box, sealed with water resistant, pressure-sensitive tape. The total weight is approximately 30 pounds. Figure 2-1 is an exploded view showing typical packing of Carry Case CY-1067D/PMQ-3.

b. Removing Contents. Perform all the steps outlined below when unpacking equipment fiberboard cartons.

(1) Slit the waterproof, pressure-sensitive sealing on the outer carton.

(2) Open the outer carton and remove the technical manual.

(3) Remove the top pad, the two end pads, back pad, and front cell, then remove the case from the carton.

2-2. Checking Unpacked Equipment

(fig. 1-1)

a. Check the components of Wind Measuring Set AN/PMQ-3A against the packing list.

NOTE

Report all discrepancies in accordance with TM 38750.

b. Carefully examine all components for damage or completeness. Refer to paragraph 1-3.

c. Check used or reconditioned equipment carefully to see if it has been changed by a modification work order (MWO); if so, the MWO number will appear

on the front panel near the nomenclature plate. Current MWO's are listed in DA Pam 310-7.

2-3. Removing Equipment from Case

(fig. 1-1)

a. Be careful when removing equipment from the case. To avoid bending the wind direction vane, follow the procedures outlined below.

(1) Open the equipment case cover and face the front of the case.

(2) With the left hand, grasp the trigger pistol grip handle.

(3) Place the right hand on the shaft of the anemometer wind vane, just above the windspeed indicator meter.

(4) Gently, with the left hand, lift the entire assembly until the anemometer wind vane is free of the retaining pads.

Caution: Do not attempt to pull the entire assembly out of the case at this time.

(5) Gently free the front extension shaft of the anemometer wind vane from the retaining pad. Be careful not to exert force which will damage the anemometer wind vane.

(6) Lift the entire unit assembly out of the case.

b. When the instrument is returned to the carrying case after use, the wind direction vane must be locked in the 0-360° position and the anemometer wind vane must be centered between the two pads and pushed downward. The lid will not close unless the vane assembly rests on the bottom of the case.

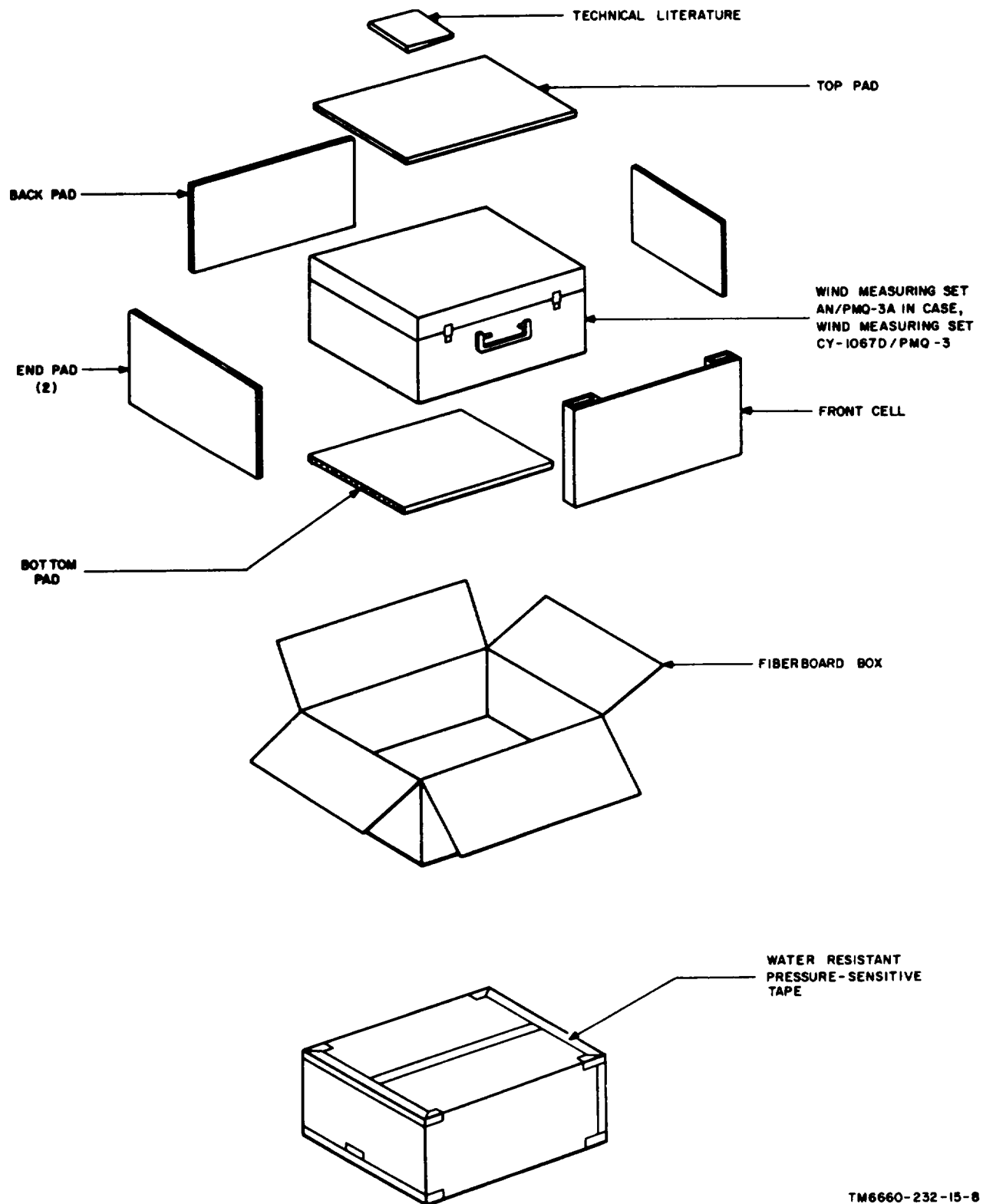

TM6660-232-15-8

Figure 2-1. Packing diagram for Carrying Case CY-1067D/PMQ-3, exploded view.

2-4. Installing Transmitter

(fig. 1-3)

a. Remove the transmitter from the retaining pad in the carrying case.

b. Place the transmitter on top of the shaft of the anemometer wind vane, and with a firm downward push, engage the transmitter while turning clockwise. Be sure that the transmitter is down and completely engaged.

c. Check the operation of the transmitter by holding the anemometer wind vane in a horizontal position, exposed to the airstreams, while viewing the indicator. Some reading should be indicated; if no reading is indicated, check to see if the transmitter is engaged as described in b above.

2-5. Siting

Proper operation of the instrument and accurate readings require a location where there will be unobstructed windflow from all directions. The location to be selected should have no obstructions in the line of sight between the operator and the reference point.

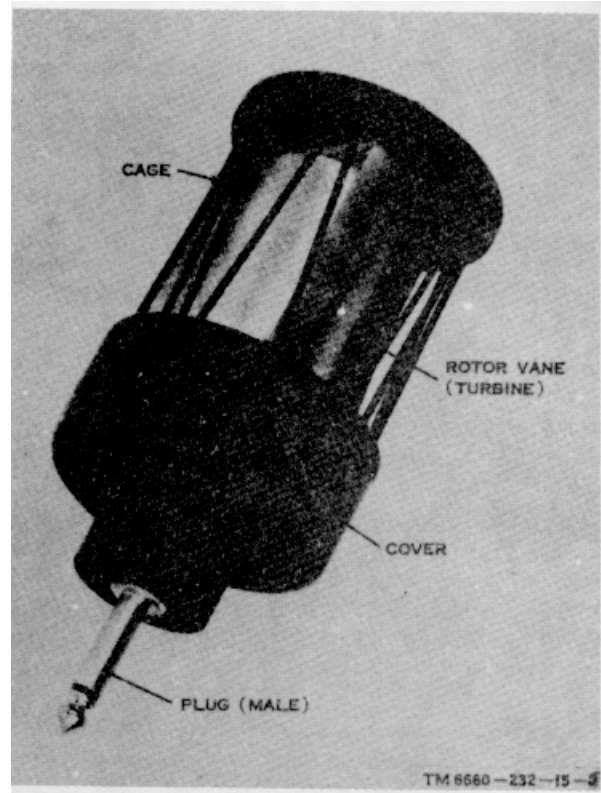

Figure 2-2. Wind Speed Transmitter T-321A/PMQ-3.

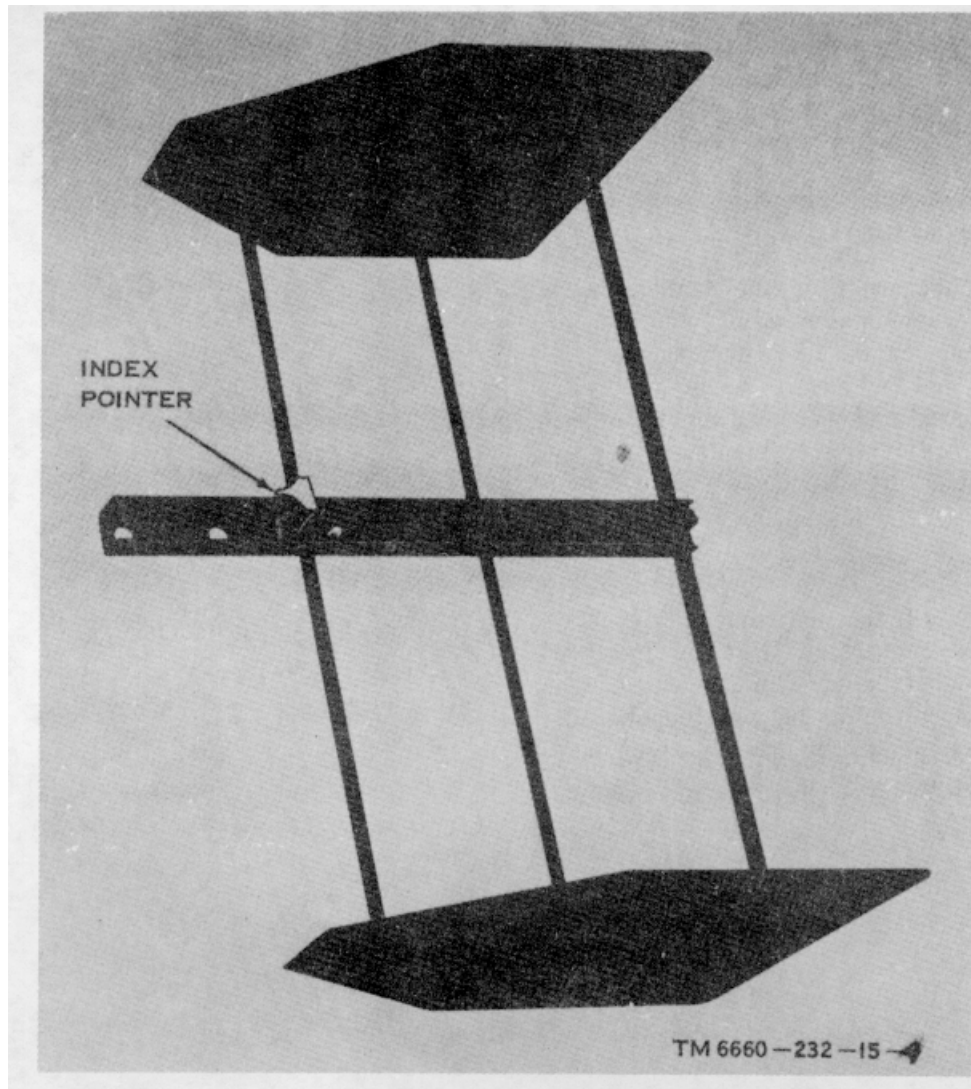

Figure 2-3. Wind Vane MIL-447A/PMQ-3.

Section II. OPERATING INSTRUCTIONS

2-6. Principles of Operation

a. *Transmitter, Wind Speed T-321A/PMQ3* (fig. 2-2). The windspeed system consists of a wind-driven turbine directly coupled to the armature of the ac generator, the voltage output of which is directly proportional to the speed of the armature. The wind striking the blades drives the turbine at a proportional rate to the speed. This generated voltage is

measured by a voltmeter calibrated to measure windspeed in knots.

b. *Windspeed Indicator* (fig. 1-3). The windspeed indicator (voltmeter) has dual scale. One scale has a range from 0 to 15 knots and the other has a range from 0 to 60 knots. The range selecting switch (in the normal position (open)) indicates windspeed values on the 0- to 60-knot scale. When the range

selector switch is closed, windspeeds are indicated on the 0- to 15-knot scale.

c. *Wind Direction Vane Assembly* (fig. 1-3).

(1) When the equipment is exposed to an airstream, the brake is released by depressing the vane lock trigger (fig. 5-1). The force of the air striking the wind direction vane (fig. 1-3) causes the direction vane assembly to align with the airstream and the index pointer to indicate a degree of marking on the direction dial (fig. 5-1).

(2) The 0-180° centerline of the direction dial is aligned parallel with the centerline of the sight, so when the instrument is sighted on a fixed point, the indication on the direction dial is the wind measurement of the direction in degrees from that point. Then the vane lock trigger is released, the brake is engaged, which prevents the direction vane assembly from rotating and locks the reading in the position for examination and recording.

2-7. Operational Procedures

After a site has been selected and the wind measuring set has been assembled, prepare it for operation as described below.

a. Grasp the wind measuring set by the handle (fig. 1-3), holding it vertically and at arms length, with sight at eye level.

b. Aim the wind measuring set at a fixed orientation point by aligning the center of the slot in the front sight with the center of the opening in the sight nearest the eye.

c. Press and hold the vane lock trigger (fig. 5-1).

d. Observe the reading on the 0- to 60-knot scale on the windspeed indicator.

e. If the windspeed reading is less than 15 knots as indicated on the upper scale, press the range selector trigger switch (fig. 1-3); observe and record the indication on the 0 to 15-knot (inner) scale.

Note. If a windspeed reading is not indicated on either of the two scales, replace the transmitter with the spare, and repeat the operational procedures.

f. The instant the windspeed is read, release the vane lock trigger.

g. Lower the wind measuring set. Read and record the wind direction as indicated by the pointer (fig. 1-3) on the azimuth dial.

Note. Be careful not to disturb the position of the wind vane until the direction reading is made and recorded.

Section III. OPERATION UNDER UNUSUAL CONDITIONS

2-8. Operation in Arctic Climates

Subzero temperatures and climatic conditions associated with cold weather affect the operation of the wind measuring set. Following are instructions and precautions for operating under such adverse conditions.

a. Snow crystals, snow, or frost may become attached to the window, wind vane, hub, or the tail vane and cause inaccurate observations or readings. Remove the ice carefully to prevent damage to the wind vane and transmitter.

b. Clean and dry the components before putting them in operation.

c. Lubricate the transmitter once every 6 months or if the transmitter operates in a sluggish manner. Refer to paragraph 4-5.

2-9. Operation in Tropical Climates

Moisture conditions are acute in tropical or swampy areas. The high relative humidity causes condensation on the equipment when the temperature of the equipment is lower than the surrounding air. Be sure to dry all components of the equipment before operation. Make frequent preventive maintenance checks on all moving parts to minimize the possibility of rust or corrosion. Check the transmitter shaft and wipe dry before inserting in the shaft end of the wind vane.

2-10. Operation in Desert Climates

The most serious problem in desert areas is sand, dust, and grit which enters the moving parts of the equipment. Make frequent preventive

maintenance checks and follow the procedures below.

a. Remove any dirt, dust, and grit from the anemometer wind vane and transmitter with a clean cloth. If the transmitter seems to operate sluggishly, return the item to a higher category for maintenance and replace the transmitter with the spare located in the case.

b. If the equipment has been in use for a long

time, dust and grit may clog the transmitter and vane trigger lock mechanism. Clean the transmitter with a soft clean cloth and lubricate the instrument (para 4-5), if necessary. Remove the indicator as described in paragraph 4-12 and clean the mechanical linkages with a soft clean cloth.

c. Apply a thin coat of antistick compound to the sealing surfaces of all containers.

CHAPTER 3

OPERATOR'S MAINTENANCE INSTRUCTIONS

3-1. Scope of Operator's Maintenance

The maintenance duties assigned to the operator of Wind Measuring Set AN/PMQ-3A are listed below, together with the reference to the paragraph covering the specific maintenance function.

- a. Daily preventive maintenance checks and services (para 3-5).
- b. Cleaning (para 3-6).
- c. Repair or replacement of parts (para 3-8).

3-2. Tools and Materials Required for Maintenance

- a. *Tools.* No tools are required to perform operator's maintenance.
- b. *Materials.*
 - (1) Clean cloths.
 - (2) Emery cloth.
 - (3) Cleaning Compound (NSN 6850-00-597-9765).

3-3. Preventive Maintenance

Preventive maintenance is the systematic care, servicing, and inspection of equipment to prevent the occurrence of trouble, to reduce downtime, and to assure that the equipment is serviceable.

a. *Systematic Care.* The procedures given in paragraphs 3-1 through 3-8 cover routine systematic care and cleaning essential to proper upkeep and operation of the equipment.

b. *Preventive Maintenance Checks and Services.* The preventive maintenance checks and services chart (para 3-5) outlines functions to be performed at specific

intervals. These checks and services are to maintain Army electronic equipment in a combat-serviceable condition; that is, in good operating condition and in general (physical) condition. To assist operators in maintaining combat serviceability, the charts indicate what to check, how to check, and the normal conditions. The References column lists the illustrations, paragraphs, or manuals that contain detailed repair or replacement procedures. If the defect cannot be remedied by the operator, a higher category of maintenance or repair is required. Records and reports of these checks and services must be made in accordance with the requirements set forth in TM 38-750.

3-4. Operator's Preventive Maintenance Checks and Services Periods

a. Preventive maintenance check and services of Wind Measuring Set AN/PMQ-3A are required on a daily and monthly basis.

b. Paragraph 3-5 specifies checks and services that must be accomplished daily and under the special conditions as outlined below.

- (1) When the equipment is initially installed.
- (2) When the equipment is reinstalled after repair or removal.
- (3) Before the equipment is packed in the carrying case.
- (4) At least once a month if the equipment is to be maintained in a standby condition.

3-5. Operator's Daily Maintenance Checks and Services Chart

<i>Sequence No.</i>	<i>Item to be Inspected</i>	<i>Procedure</i>	<i>References</i>
1	Completeness-----	See that the item is complete.	Para 1-6.
2	Cleanliness -----	Clean all components of equipment.	Para 3-6.
3	Metal surfaces -----	Check anemometer wind vane, transmitter, wind vane, including spares for corrosion or deterioration.	Para 3-6.
4	Meter and azimuth dial-----	Check meter glass for cracks or breaks and check indicator dial for legible markings.	Fig. 1-3 and 5-1.
5	Installation-----	Check to see that the transmitter fits properly and the windspeed indicator operates.	Para 2-4.
6	Mechanical operation-----	Check the vane lock trigger mechanism for braking action. Check trigger toggle switch for operation. Check nose vane for proper balance; adjust if necessary.	Para 2-6 and 2-7.
7	Case and accessory equipment ----	Check case lock fasteners for tightness and rubber gasket for breaks. Check to see that the Bristol spline wrenches, wind vane, and transmitter are present, secure, and in good condition.	Fig. 1-1.

3-6. Cleaning

Under normal (dry) weather conditions, all components can be conveniently cleaned and inspected in the field after use or repacking. For adverse weather (wet) conditions, cleaning and inspection will be performed under shelter. Remove dust, dirt, moisture, grease, fungus, and any other foreign matter from all surfaces including joints, hooks, and points where two or more pieces are connected as indicated in a and b below.

a. Remove dust and loose dirt from metal surfaces with a clean soft cloth.

Caution: Allow surfaces to dry before cleaning.

b. Remove dust and loose dirt from nonmetal surfaces with a clean soft brush.

Warning: Prolonged breathing of cleaning compound is dangerous; make sure that adequate ventilation is provided. Cleaning compound is flammable; do not use near a flame. Avoid contact with the skin; wash off any that spills on your hands.

c. Remove grease, fungus, and ground-in dirt from all metal surfaces; use a clean cloth dampened

(not wet) with cleaning compound. Wipe with a clean dry cloth.

d. Spot clean nonmetal surfaces with soap and water; allow to dry thoroughly before packing.

e. To remove rust and corrosion from metal surfaces, sand them lightly with a fine emery cloth. Brush two thin coats of paint on the bare metal to protect it from further corrosion. Refer to applicable cleaning and refinishing practices specified in TB SIG 364.

3-7. Operator's Troubleshooting Chart

All corrective measures that the operator can perform are given in the preventive maintenance checks and services chart (para 3-5). If the item inspected requires repair or replacement above the scope outlined, then additional maintenance must be performed at a higher category of maintenance.

3-8. Repair or Replacement

a. Replace the transmitter or wind vane from the spare parts when inspection reveals damage has rendered the unit unserviceable.

b. Repair or replacement of any other part or assembly which inspection indicates has been damaged to the extent that repair will be required before it can be

considered serviceable will be accomplished at organizational maintenance or as indicated in the maintenance allocation chart (app C).

CHAPTER 4

ORGANIZATIONAL MAINTENANCE

Section I. PREVENTIVE MAINTENANCE

4-1. Scope of Preventive Maintenance

a. This chapter contains instructions for organizational maintenance, periodic maintenance services, and repair functions to be accomplished by the organizational repairman. Also included are sections on troubleshooting and circuit functions.

b. Organizational maintenance of Wind Measuring Set AN/PMQ-3A includes the following: (1) Monthly preventive maintenance (para 4-4).

- (2) Quarterly preventive maintenance (para 4-7).
- (3) Removal and replacement of toggle switch.
- (4) Removal and replacement of wind vane (para 4-12).

4-2. Tools, Materials, and Test Equipment Required

The tools, materials, and test equipment required are listed below.

a. *Tools.* All tools required are in Tool Kit, Operations Central TK-101/G.

- b. *Materials.*
- (1) Lint-free cloth.
 - (2) Cleaning brush.
 - (3) Cleaning compound (NSN 6850-00-597-9765).
 - (4) Antistick compound.
 - (5) Lubrication Oil, Instrument (OAI) (NSN 9150-00-257-5449).

c. *Test Equipment.* The only test equipment required is Multimeter AN/URM-106.

4-3. Preventive Maintenance

Preventive maintenance is the systematic care, inspection, and servicing of the equipment to maintain it in a serviceable condition, prevent breakdowns, and assure maximum operational capability. Preventive maintenance is the responsibility of all maintenance categories concerned with the equipment and includes the inspection, testing, and repair or replacement of parts, subassemblies, or units that inspection and test indicate would probably fail before the next scheduled periodic service. Preventive maintenance services and inspections of Wind Measuring Set AN/PMQ-3A at the organizational category are made at scheduled intervals unless otherwise directed by the commanding officer.

4-4. Monthly Preventive Maintenance

Perform the maintenance functions indicated in the monthly preventive maintenance checks and services chart (para 4-6). A month is defined as 30- calendar days of 8 hours per day operation. Adjustment of the maintenance interval must be made to compensate for unusual operating conditions. Equipment maintained in a standby (ready for immediate operation) condition must have monthly preventive maintenance checks and services performed on it. Equipment in limited storage (requires service before operation) does not require monthly maintenance.

4-5. Lubrication

Lubrication of the windspeed transmitter is required at least once every 6 months, or whenever sluggish movement indicates a need for lubrication. Perform lubrication as indicated below.

- a. Remove the screws and washers from the bottom of the cage housing (fig. 6-1) and pull off the cover.
- b. Use a wooden toothpick, or pin, and apply 1 drop of watch oil to the bottom bearing.

- c. Remove the two screws from the bearing cover and apply 1 drop of watch oil to the top bearing.
Caution: Overlubrication is detrimental to the instrument. Do not make any adjustments.

4-6. Monthly Preventive Maintenance Checks and Services Chart

<i>Sequence No.</i>	<i>Item to be Inspected</i>	<i>Procedure</i>	<i>References</i>
1	Completeness-----	Check for complete unit, including spares.	Para 2-2 and fig. 1-1.
2	Cleanline -----	Unit must be clean and dry, inside and out, and free of dirt, grime, corrosion, and fungus.	Para 3-6.
3	Preservation -----	Painted surfaces must be free of bare spots, rust, and corrosion.	Para 3-6.

4-7. Quarterly Maintenance

a. Quarterly preventive maintenance checks and services on Wind Measuring Set AN/PMQ3A are required. Periodic weekly and monthly services constitute a part of the quarterly preventive maintenance

checks and services and must be performed concurrently.
 b. Maintenance forms and records to be used and maintained on this equipment are specified in DA Pam 738-750.

4-8. Quarterly Preventive Maintenance Checks and Services Chart

<i>Sequence No.</i>	<i>Item to be Inspected</i>	<i>Procedure</i>	<i>References</i>
1	a. Completeness-----	a. Equipment must be complete.	a. Para 2-2 and app B.
	b. Proper installation-----	b. Installation is in accordance with paragraphs 2-5 and 3-5.	b. Fig. 1-3.
	c. Cleanliness -----	c. Unit must be clean and dry, inside and out; free of dirt, grime, rust, fungus, and corrosion.	c. Para 3-6.
	d. Preservation -----	d. Painted surfaces must be free of bare spots, rust, and corrosion.	d. Para 3-6.
2	Publications-----	a. See that publications are complete, serviceable, and current.	a. App A.
		b. All changes pertinent to the equipment are on hand.	b. DA Pam 310-1.
3	Modification work orders-----	Determine if new applicable MWO's have been published. All URGENT MWO's must be applied immediately. All NORMAL MWO's must be scheduled.	DA Pam 310-1.
4	Dials, knobs, and switches-----	Check for proper mechanical action by setting each control through each of its settings. Action is positive without backlash, binding, or scraping.	Para 3-5.
5	Lubrication -----	Mechanisms should not show signs of overlubrication or under lubrication.	Para 4-5.
6	Transmitter-----	a. Nose vane is free and smooth.	Para 2-4.
		b. Transmitter moves freely.	
		c. Tail vane is free of dents and is in good condition.	

Section II. TROUBLESHOOTING

4-9. General

Troubleshooting the equipment is based on the operational checks in the quarterly preventive maintenance checks and services chart (para 4-8). To troubleshoot the equipment, perform the operator's

checks and services (para 3-5) and proceed until an abnormal condition or result is observed, then refer to the corresponding trouble in the troubleshooting chart. Perform the checks and corrective measures indicated. If the corrective measures do not result in correction of the trouble, higher category of maintenance is required.

4-10. Troubleshooting Chart

<i>item No.</i>	<i>Trouble symptom</i>	<i>Probable trouble</i>	<i>Checks and corrective measures</i>
1	No pointer movement in 0-60 or 0-15 range.	Defective transmitter.	Replace transmitter.
2	No pointer movement in 0-60 range only.	Defective windspeed indicator.	Replace indicator (para 4-11).
3	No pointer movement in 0-15 range only.	a. Defective speed indicator. b. Defective switch or windspeed indicator.	a. Replace indicator (para 4-11). b. Connect terminals of switch together; if no indication is obtained, refer to a higher maintenance category for repair.
4	Pointer does not rest on zero when turbine is stationary.	Windspeed indicator not properly zeroed.	Turn zero adjustment on front of indicator (fig. 1-3).
5	Sluggish pointer movement.	Dirty or damaged windspeed indicator.	Replace indicator (para 4-11).

4-11. Removal and Replacement of Windspeed Indicator (fig. 5-2)

- a. Remove the three screws that hold the housing plate.
- b. Lift off the cover plate and rubber washers.
- c. Carefully pull out the windspeed indicator.
- d. Remove the terminal board from the indicator by removing the screws and lockwashers from the terminals on the rear of the indicator. Make a continuity check of all leads before tagging.
- e. Replace the windspeed indicator and leads, then fasten the terminal board with the screws and lockwashers.
- f. Replace the cover.

Caution: Before placing the screws in the cover, be sure to replace the rubber washers on the screws between the meter and the housing. This will secure the windspeed indicator and prevent damage.

- g. Replace the three screws.

- h. Adjust the meter to a zero reading with the adjusting screw on the faceplate of the indicator (fig. 1-3). Hold the transmitter in the operating position while making the final zero adjustment.

4-12. Removal and Replacement of Wind Tail Assembly (fig. 2-3)

- a. Remove the two screws and lockwashers that secure the tail assembly to the hub and separate the vane tail assembly from the anemometer wind vane.
- b. Remove the spare vane tail assembly from the carrying case and attach the assembly to the instrument; use the two screws that were removed as instructed in a above.
- c. Balance the assembled wind vane tail assembly (fig. 1-3) as follows:
 - (1) Hold the anemometer wind vane in a horizontal position.
 - (2) Press the vane lock trigger and loosen the jamnut.

(3) Screw the vane nose in or out until the vane is balanced.

(4) Make sure the jamnut is taut when testing for balance.

Section III. CIRCUIT FUNCTIONS

4-13. General Functions

a. Wind Measuring Set AN/PMQ-3A is a portable, hand-held, direct-reading wind measuring system which gives visual indications of wind direction through 360° and windspeed from 0 to 60 knots.

b. A wind turbine in the windspeed transmitter drives an ac generator which applies a voltage to a voltmeter for measuring and indicating windspeed. An index pointer, which is part of the wind vane, indicates wind direction measurements on a circular dial. The dial is attached to and concentric with the vertical extension tube on the anemometer wind vane. A vane lock trigger locks the direction measurements for examination.

4-14. Transmitter

a. The windspeed transmitter has a dual scale, one scale has a range from 0 to 15 knots and the other has a range from 0 to 60 knots. The range selecting switch in the normal position (open) connects the resistors in series and windspeed values are indicated on the 060 knot scale. When the switch is closed, a resistor is shorted out, reducing the voltage drop and increasing the deflection for a given generated voltage. Thus, the windspeed is indicated on the 0-15 scale.

b. Accuracy of the windspeed turbine should be within 1 1/2 knots when stopping. Windspeed indications are accurate within the following ranges:

<i>Accuracy (knots)</i>	<i>Range (knots)</i>
1	0 to 10
1 1/2	11 to 40
2	41 to 55
3	Over 55

**4-15. Wind Direction
(fig. 1-3)**

With the equipment exposed to an airstream and the brake released by depressing the vane lock trigger, the force of the air striking the vane tail causes the direction vane assembly to align with the airstream. The index pointer will indicate a degree marking on the direction dial scale. The vane will align itself within 2° in a 5-knot wind when displaced 5° from the wind stream. The 0-180° centerline of the dial is aligned parallel with the centerline of the sight. When the anemometer wind vane is sighted on a fixed point, the indication on the direction dial is the measurement in degrees from that point. Releasing the vane lock trigger engages the brake and prevents the vane assembly from rotating.

CHAPTER 5

DIRECT SUPPORT MAINTENANCE

Section I. GENERAL

5-1. Scope of Direct Support Maintenance

a. This chapter contains instructions covering direct support maintenance for Wind Measuring Set AN/PMQ-3A. It includes instructions for replacement of specified maintenance parts and instructions covering the troubleshooting and subsequent repair procedures to be accomplished by direct support maintenance personnel. This section supplements those instructions in previous chapters of this manual. This chapter provides replacement procedures which must be performed at direct support category. Operating instructions are included in paragraphs 2-6 and 2-7.

b. Direct support maintenance of Wind Measuring Set AN/PMQ-3A includes the following:

(1) Removal and replacement of toggle switch.

(2) Removal and replacement of trigger assembly, including springs and wiring.

(3) Repair of carrying case latches, hinges, handles, and padding.

5-2. Tools, Materials, and Test Equipment Required for Direct Support

a. Tools. All tools required are in Tool Kit, Electronic Equipment TK-100/G.

b. *Materials.*

(1) Lint-free cloth.

(2) Cleaning brush.

(3) Cleaning compound.

(4) Lubricating Oil, General Purpose (FED VV-L800).

c. *Test Equipment.* The only test equipment required is Multimeter TS-352B/U.

Section II. DIRECT SUPPORT TROUBLESHOOTING AND REPAIR PROCEDURES

5-3. Organization of Troubleshooting Procedures

a. *General.* The first step in servicing a defective equipment is to sectionalize the fault. Sectionalization means tracing the fault to the major component. The second step is to localize the fault. Localization means tracing the fault to the defective section of a particular component. The third step is isolating the fault to the defective part. Some faults such as meter indications or binding of mechanical components can be isolated by sight or hearing. The majority of faults must be isolated by detailed mechanical checks.

b. *Sectionalization.* Check. When an opera

tional test (para 3-5 and 4-8) indicates that a component is faulty, the procedures described below will often lead maintenance personnel direct to the source of trouble.

(1) *Visual inspection.* The purpose of visual inspection is to locate the faults without test or measurements. All visual signs should be analyzed to help localize the fault to a particular component. Mechanical faults are most often localized through visual inspection.

(2) *Replacement parts.* A defective trigger assembly will affect windspeed and wind direction readings. Remove suspected parts and visually inspect and replace defective parts with identical ones known to be good.

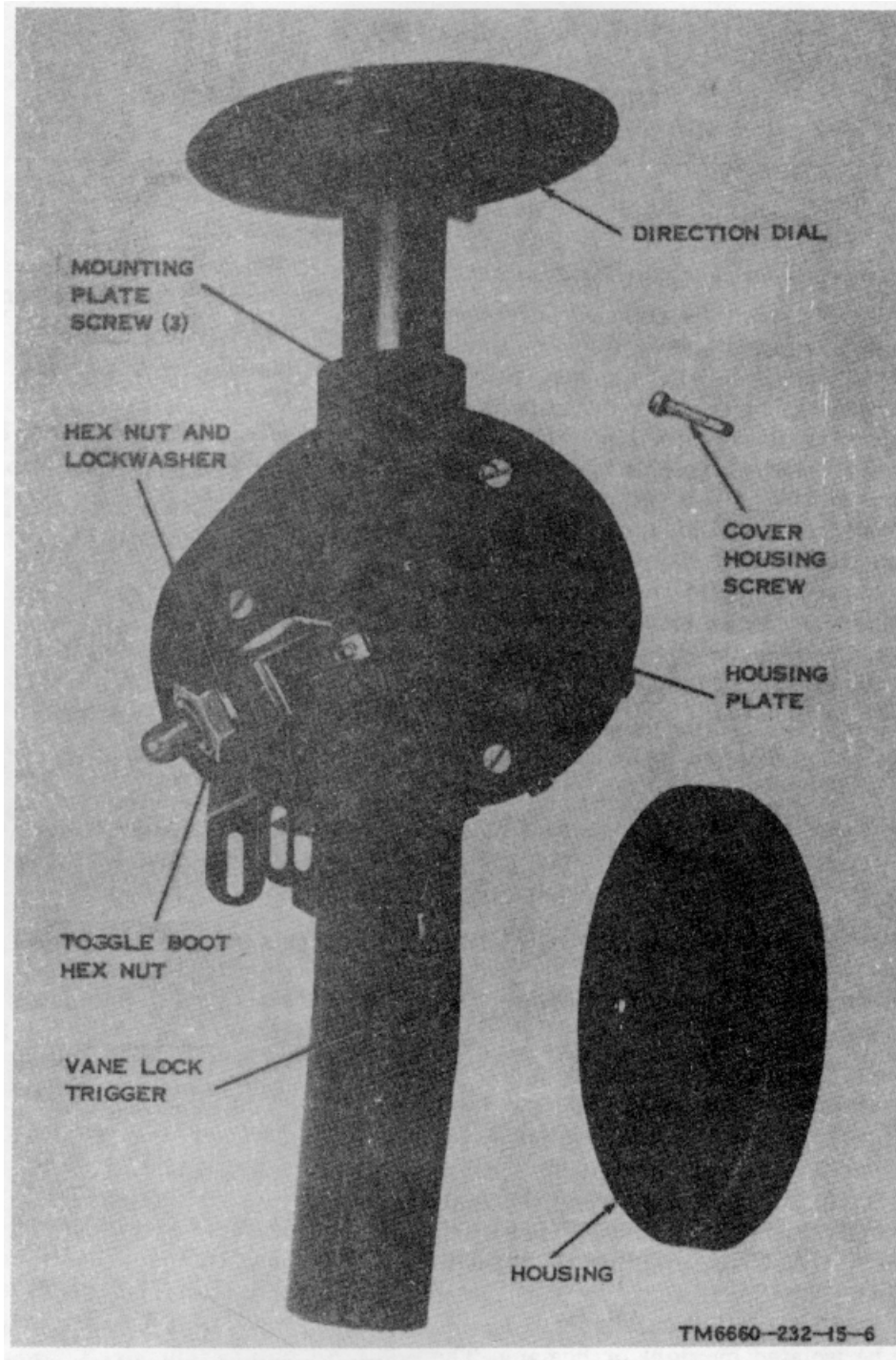

Figure 5-1. Anemometer Wind Vane ML-446A/PMQ-3 with cover off.

5-4. Removal and Replacement of Toggle Switch (fig. 5-1)

- a. Remove the screw from the center of the rear cover, lift off the cover.
- b. Remove the protective toggle switch boot by turning the hexagonal nut counterclockwise.
- c. Carefully pull the coated hexagonal nut and toggle boot off the switch.
- d. Remove the hexagonal nut and lockwasher that hold the microswitch to the carrying case.
- e. Gently remove the toggle switch away from the case.
- f. Remove the screws on the top of the switch; make a continuity check of all the leads between the transmitter, windspeed indicator, and toggle switch before tagging.
- g. Replace the switch and the leads, tighten the hexagonal nut that holds the switch to the case, and replace the protective hexagonal nut and cover.

5-5. Removal and Replacement of Trigger and Switch Assembly (fig. 5-2)

If any part of the trigger and switch assembly is defective, replace the complete unit as follows:

- a. Remove the screw from the rear cover (fig. 4-1), and lift off the cover.
- b. Remove the three cover plate screws from the front panel of the indicator, and lift off the cover plate.
- c. Carefully pull out the windspeed indicator.

- d. Lift the trigger reclaiming spring from the plate hook.
- e. Use the #4 Bristol, six-fluted, spline-type wrench (fig. 1-2) in the top of the case and loosen the two setscrews until the plunger is disengaged from the vertical rod.
- f. Remove the three screws (fig. 5-1) from the edge of the switch mounting plate.
- g. Remove the toggle switch.
- h. Lift the trigger and switch assembly from the housing, sliding the plunger from the vertical rod.
- i. Replace the trigger and switch assembly.
- j. Replace the toggle switch and connect the tagged leads.
- k. Insert a 0.015-inch shim (horseshoe-type preferred) between the brake and the vane mounting hub (fig. 1-3).
- l. Align the float of the plunger with the setscrews; the setscrews must be loose.
- m. Replace the three screws on the switch mounting plate.
- n. Hold the brake against the vane mounting hub, press the vane lock trigger until it comes against its stop.
- o. Hold this position and tighten the setscrews.
- p. Release the trigger and remove the shim.
- q. Install the trigger retaining spring by holding the anemometer vane upside down for ease in hooking the spring loop.
- r. Replace the rear cover, the speed indicator, and the front panel cover.

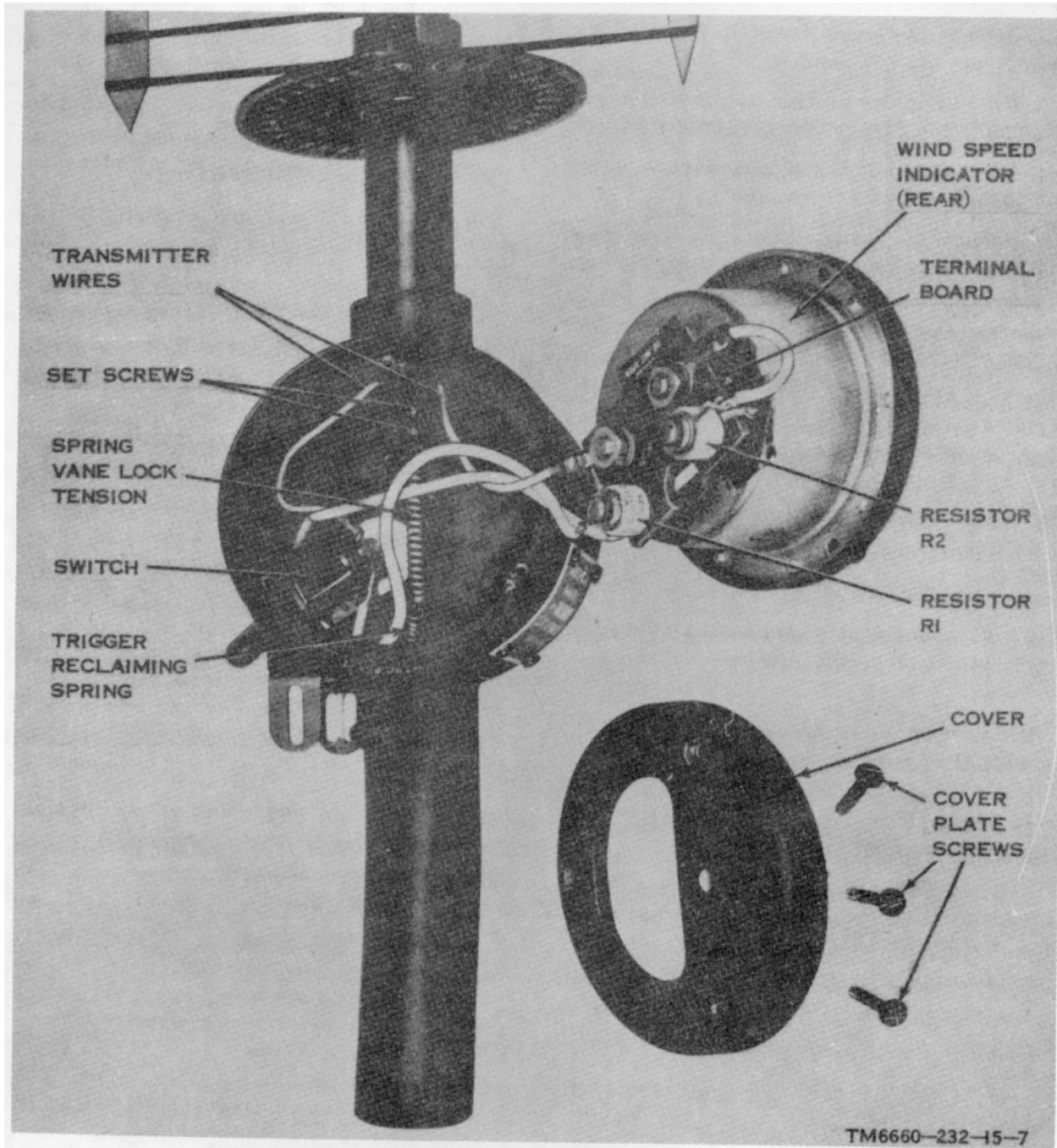

Figure 5-2. Anemometer Wind Vane MIL-446A/PAQ-3, interior view.

CHAPTER 6

GENERAL SUPPORT MAINTENANCE

6-1. Scope of General Support Maintenance

a. This chapter contains instructions covering general support maintenance for Wind Measuring Set AN/PMQ-3A and includes instructions for replacement of specified maintenance parts. The instructions cover trouble-shooting and subsequent repair procedures to be accomplished by the general support maintenance personnel. This chapter supplements those instructions in the previous chapters of this manual. This chapter provides repair and replacement procedures which must be performed at the general support category. Operating instructions are included in paragraphs 2-6 and 2-7.

b. General support maintenance of Wind Measuring Set AN/PMQ-3A includes the following:

- (1) Repair of windspeed transmitter.
- (2) Repair of trigger assembly.

6-2. Tools, Materials, and Test Equipment Required for General Support

a. *Tools.* All tools required for general support are in Tool Kit, Electronic Equipment TK-100/G.

b. *Materials.*

- (1) Clean cloths.
- (2) Emery cloth.
- (3) Cleaning compound (NSN 6850-00-597-9765).

- (4) Cleaning brush.
- (5) Oil (FED VV-L-800).

c. *Test Equipment.* The only test equipment required is Multimeter TS-352B/U.

6-3. Repair of Windspeed Transmitter
(fig. 6-1)**NOTES**

If performance check, paragraph 9, TB 116660-232-35, cannot be met, replace coils by the following procedure.

a. Remove the windspeed transmitter from the vertical shaft of the anemometer wind vane. Disassemble the transmitter as follows: (1) Remove the four screws and lockwashers from the generator housing.

(2) Remove the pillars from the cage housing.

(3) Remove fixed resistor R1; unsolder and tag the leads as they are removed.

(4) Remove the machine screw from the top of the fixed resistor.

(5) Remove the screws from the coil retaining plate and replace the generator coil.

(6) Unsolder the jumper leads and tag the leads as they are removed. Slide the coil assembly out from the turbine shaft and replace. Resolder leads and replace all screws.

b. Remove and replace the rotor vane assembly (fig. 1-3) as follows: (1) Remove four screws and washers from the top of the cage housing.

(2) Remove two machine screws from the top of the bearing cap.

(3) Remove the top cover and setscrews and slide off the rotor vane.

(4) Replace the vane and adjust for clearance with the setscrews; replace the top of the cage housing and screws.

6-4. Repair and Adjustment of Trigger Assembly
(fig. 5-2)

a. Some of the parts in the trigger assembly can be reached and replaced without disassembly or special tools.

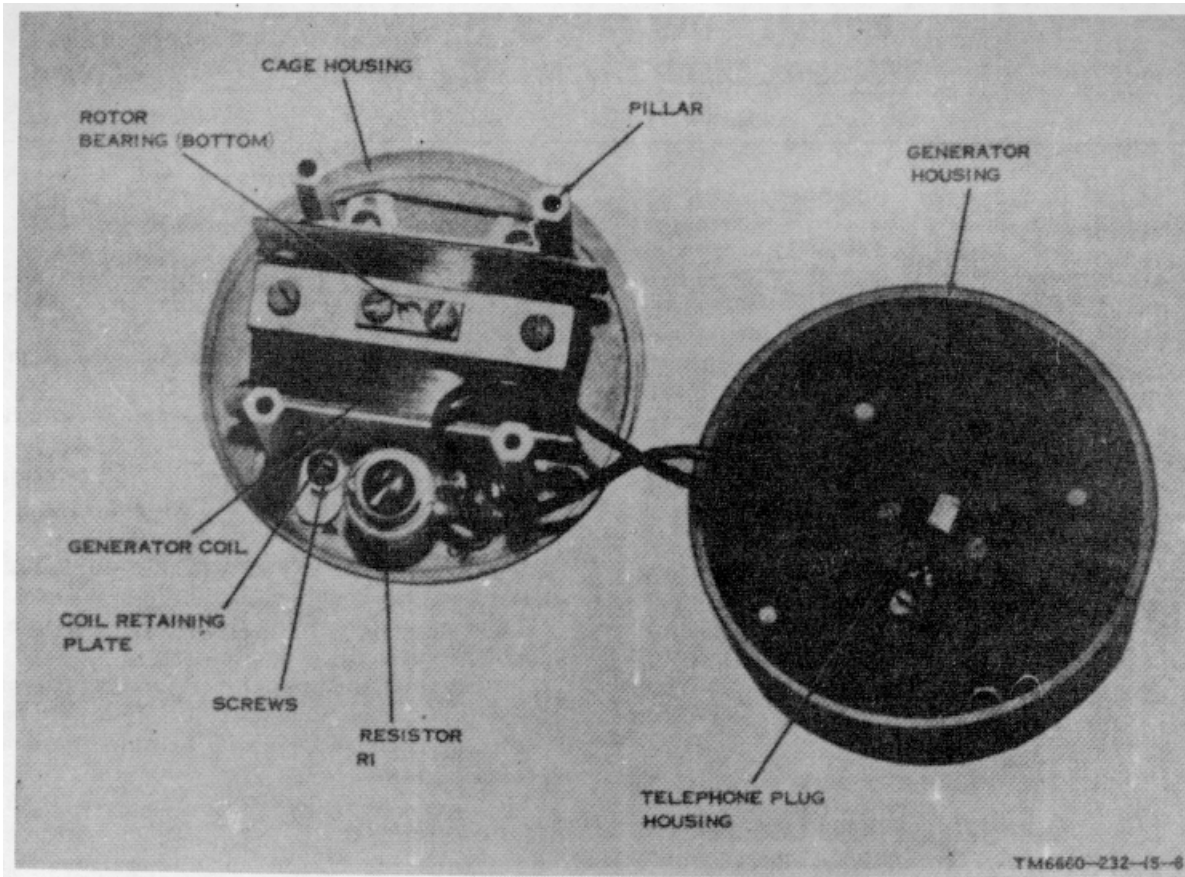

Figure 6-1. Windspeed Transmitter, Partial Disassembly.

b. Sectionalizing trouble in the equipment can simplify repairs by limiting the work to the defective area. Repairs that can be made by disassembly of the particular parts that operate as a group to perform a function are outlined in (1), (2), and (3) below.

(1) Repairs to the trigger assembly tension can be made by replacing the trigger reclaiming spring without removing the trigger and switching mechanism.

(2) Adjustments to the braking mechanism can be made by loosening the setscrews with the Bristol #4 spline wrenches and following the procedures outlined in paragraph 5-5.

(3) Replacement of the trigger shaft and spring will require removal of trigger and switch assembly (para 5-5).

6-5. Removal and Replacement of Wind Dial Assembly

(fig. 1-3)

If the wind dial assembly has been bent or damaged, replace the dial as follows:

a. Remove the transmitter from the anemometer wind vane.

b. Remove the screw from the rear cover (fig. 5-1) and lift off the cover.

c. Remove the three cover plate screws from the front panel of the windspeed indicator and lift off the cover plate.

d. Carefully pull out the windspeed indicator (fig. 5-2) and disconnect the transmitter wires from the indicator and toggle switch.

e. Remove the three screws (fig. D-1) from the anemometer body assembly.

f. Remove the jack assembly with the transmitter wires from the body.

Caution: Do not pull the wires completely out from the body assembly; only enough to remove the setscrews in the ring vane brake.

g. Remove the setscrews in the ring vane brake, then drive out the pin that holds the ring vane brake.

h. Remove the ring vane from the anemometer wind vane assembly.

i. Remove and replace the wind direction dial.

j. Replace the wind vane assembly and the ring vane. Place the pin back in the ring vane assembly and hammer it in until it is flush with the body assembly.

k. Replace and tighten the setscrews, then gently pull the transmitter wires down through the body assembly until the jack assembly is seated.

l. Replace the screws that hold the jack assembly to the anemometer wind vane, then replace the transmitter wires, the cover plate screws, the cover plate, and the rear cover.

CHAPTER 7

DEPOT MAINTENANCE

7-1. Scope of Depot Maintenance

This chapter contains instructions for depot maintenance of Wind Measuring Set AN/ PMQ-3A. These instructions supplement those appearing in the preceding chapters of this manual. Operating instructions are included in paragraphs 2-6 through 2-10.

7-2. Tools, Materials, and Test Equipment Required for Depot Maintenance

a. Tools. All tools required for depot maintenance are in Tool Kit, Electronic Equipment TK-100/G.

b. Materials.

(1) Clean cloths.

(2) Cleaning compound (FSN 7930-395-9542).

c. Test Equipment. Refer to the maintenance allocation chart (app C) for test equipment and procedures used in the calibration of Wind Measuring Set AN/PMQ-3A.

7-3. Depot Maintenance Standards

a. Depot maintenance, including rebuilding and overhauling of Anemometer Wind Vane ML-446A/PMQ-3, will be made after a technical inspection performed by the maintenance shop on material turned in for repair. The technical inspection determines the extent of repairs required, and provides the basis for requisitioning the parts, assemblies, or supplies necessary to accomplish the repairs.

b. Inspection will determine the classification of the equipment as follows:

(1) Serviceable. Serviceable material consists of all new or used supplies which are in condition for issue for the purpose intended and all supplies which can be placed in such

condition through preissue tests or inspection, in storage deprocessing, installation of accessories, correction of minor deficiencies which have developed since the item was last classified as serviceable, and application of modification work orders for which parts are available or assembly of available components.

(2) Unserviceable. Unserviceable material consists of all supplies which are not serviceable. The definition of unserviceable material is further broken down into the following subclassifications: Material which is unserviceable but economically repairable, material which is unserviceable and not economically repairable.

7-4. Depot Maintenance of Windspeed Transmitter

a. Check to see that the transmitter is free of defects as determined in the preventive maintenance schedule in paragraph 48. Refer to paragraph 6-3 for repair of defects.

b. Repair and rebuild procedures for the transmitter consists of replacing any part which has been determined to be unserviceable. No procedures are recommended for restoring any unserviceable parts to good condition, only total replacement of defective parts is recommended.

c. After rebuilding and reassembly, the windspeed transmitter will be tested and calibrated with the windspeed indicator assembly in accordance with the test and calibration procedures. Refer to paragraphs 2-6 and 2-7 for operating instructions.

7-5. Depot Maintenance of Anemometer Wind Vane

a. Check to see that the anemometer wind vane is free of defects as determined in the

preventive maintenance schedule in paragraphs 3-5 and 4-8. Refer to paragraphs 4-10 and 5-3 for troubleshooting procedures. Refer to paragraphs 4-11, 5-4, 5-5, 6-4, and 6-5 for repair of defects.

b. Repair and rebuild procedures consists of replacing any part which has been determined to be unserviceable. No procedures are recommended for restoring any unserviceable parts to good condition, only total replacement of defective parts is recommended.

c. Reassembly of anemometer wind vane components will be made in accordance with the procedures in paragraphs 4-11, 5-4, 5-5, 6-4, and 6-5. Refer to paragraphs 2-6 through 2-10 for operating instructions.

d. The test and calibration procedures are covered in detail in TB 11-6660-232-15/2 and the test equipment is listed in the maintenance allocation chart (app C).

CHAPTER 8

SHIPMENT, LIMITED STORAGE

8-1. Disassembly of Equipment

- a. Disconnect the transmitter from the vertical support housing of the anemometer wind vane.
- b. Lock the wind direction vane in the 0-360° position.

8-2. Packing Equipment In Carrying Case

Preventive maintenance procedures (para 4-5) should be performed before the equipment is repacked in its carrying case for any extended period of time. When inspection and cleaning has been completed, place each piece in its appropriate place in the carrying case (fig. 1-1) as follows:

- a. Place the anemometer wind vane in the case with the vertical housing support securely placed in the padded holding slot.

- b. Center the anemometer wind vane between the two pads and push downward.

- c. Place the transmitter in the carrying case, plug downward.

- d. Tighten the lid by fastening the lock fasteners and turning the screw-type fasteners clockwise.

Section II. Deleted.

Change 3 8-1/(8-2 blank)

APPENDIX A**REFERENCES**

Following is a list of applicable references which are available to maintenance personnel.

DA Pam 301-1	Consolidated Index of Army Publications and Blank Forms.
DA Pam 738-750	The Army Maintenance Management System (TAMMS).
TB 11-6660-232-35	Calibration Procedures for Wind Measuring Sets AN/PMQ-3 (NSN 6660-00-592-9002), AN/PMQ-3A (6660-00-515-4339), AN/PMQ-3B (660-00-574-4179), AN/PMQ-3C (6660-00-592-9002), and AN/PMQ-3D (660-00-964-8913).
TM 11-6625-203-12	Operator's and Organizational Maintenance Manual: Multimeter AN/URM-105 and AN/URM-105C (Including Multimeter ME-77/U and ME-77C/U).
TM 11-6625-366-15	Operator's, Organizational, Direct Support, General Support and Depot Maintenance Manual: Multimeter TS-352B/U (NSN 6625-00-553-0142).
TM 11-6660-232-15-HR	Hand Receipt Covering Contents of Components of End Item (COEI), Basic Issue Items (BII), and Additional Authorization List (AAL) for Wind Measuring Set AN/PMQ-3A (NSN 6660-00-515-4339).
TM 750-244-2	Procedures for Destruction of Electronics Materiel to Prevent Enemy Use (Electronics Command).

Change 3 A-1/(A-2 blank)

APPENDIX B

COMPONENTS OF END ITEM LIST

Section I. INTRODUCTION

B-1. Scope

This appendix lists integral components of and basic issue items for the AN/PMQ-3A to help you inventory items required for safe and efficient operation.

B-2. General

This Components of End Item List is divided into the following sections:

a. Section II. Integral Components of the End Item. These items, when assembled, comprise the AN/PMQ-3A and must accompany it whenever it is transferred or turned in. The illustrations will help you identify these items.

b. Section III. Basic Issue Items. These are the minimum essential items required to place the AN/PMQ-3A in operation, to operate it, and to perform emergency repairs. Although shipped separately packed they must accompany the AN/PMQ-3A during operation and whenever it is transferred between accountable officers. The illustrations will assist you with hard-to-identify items. This manual is your authority to requisition replacement BII, based on TOE/MTOE authorization of the end item.

B-3. Explanation of Columns

a. Illustration. This column is divided as follows:

- (1) Figure number. Indicates the figure number of the illustration on which the item is shown.
- (2) Item number. The number used to identify

item called out in the illustration.

b. National Stock Number. Indicates the National stock number assigned to the item and which will be used for requisitioning.

c. Part Number. Indicates the primary number used by the manufacturer, which controls the design and characteristics of the item by means of its engineering drawings, specifications, standards, and inspection requirements to identify an item or range of items. Following the part number, the Federal Supply Code for Manufacturers (FSCM) is shown in parentheses.

d. Description. Indicates the Federal item name and, if required, a minimum description to identify the item.

e. Location. The physical location of each item listed is given in this column. The lists are designed to inventory all items in one area of the major item before moving on to an adjacent area.

f. Usable on Code. Not applicable.

g. Quantity Required (Qty. Reqd). This column lists the quantity of each item required for a complete major item.

h. Quantity. This column is left blank for use during an inventory. Under the Rcvd column, list the quantity you actually receive on your major item. The Date columns are for your use when you inventory the major item at a later date; such as for shipment to another site.

(Next printed page is B-2)

SECTION II. INTEGRAL COMPONENTS OF END ITEM

(1) ILLUSTRATION		(2) NATIONAL STOCK NUMBER	(3) DESCRIPTION PART NUMBER (FSCM)	(4) LOCATION	(5) USABLE ON CODE	(6) QTY REQD	(7) QUANTITY	
(A) FIG. NO.	(B) ITEM NO.						RCVD	DATE
1-1		6660-00-515-4339	WIND MEASURING SET AN/PQ-3A C/O:			1		
1-3		6660-00-515-4341	ANEMOMETER WIND VANE ML-446A/PMQ-3			1		
2-3		6660-00-323-2262	WIND VANE MIL-47A/PMQ-3			2		
2-2		6660-00-515-4342	WIND SPEED TRANSMITTER T-312A/PMQ-3			2		

Change 3 B-2

SECTION III. BASIC ISSUE ITEMS

(1) ILLUSTRATION		(2) NATIONAL STOCK NUMBER	(3) DESCRIPTION PART NUMBER (FSCM)	(4) LOCATION	(5) USABLE ON CODE	(6) QTY REQD	(7) QUANTITY	
(A) FIG. NO.	(B) ITEM NO.						RCVD	DATE
1-1		6660-00-964-8980	CASE, CARRYING CY-1067D/PMQ-3			1		

Change 3 B-3/(B-4 blank)

APPENDIX C

MAINTENANCE ALLOCATION

Section I. INTRODUCTION

C-1. General

This appendix provides a summary of the maintenance operations for Wind Measuring Set AN/ PMQ-3A. It authorizes categories of maintenance for specific maintenance functions on repairable items and components and the tools and equipment required to perform each function. This appendix may be used as an aid in planning maintenance operations.

C-2. Maintenance Function

Maintenance functions will be limited to and defined as follows:

a. Inspect. To determine the serviceability of an item by comparing its physical, mechanical, and/or electrical characteristics with established standards through examination.

b. Test. To verify serviceability and to detect incipient failure by measuring the mechanical or electrical characteristics of an item and comparing those characteristics with prescribed standards.

c. Service. Operations required periodically to keep an item in proper operating condition, i.e., to clean (decontaminate), to preserve, to drain, to paint, or to replenish fuel, lubricants, hydraulic fluids, or compressed air supplies.

d. Adjust. To maintain, within prescribed limits, by bringing into proper or exact position, or by setting the operating characteristics to the specified parameters.

e. Align. To adjust specified variable elements of an item to bring about optimum or desired performance.

f. Calibrate. To determine and cause corrections to be made or to be adjusted on instruments or test measuring and diagnostic equipments used in precision measurement. Consists of comparisons of two instruments, one of which is a certified standard of known accuracy, to detect and adjust any discrepancy in

the accuracy of the instrument being compared.

g. Install. The act of emplacing, seating, or fixing into position an item, part, module (component or assembly) in a manner to allow the proper functioning of the equipment or system.

h. Replace. The act of substituting a serviceable like type part, subassembly, or module (component or assembly) for an unserviceable counterpart.

i. Repair. The application of maintenance services (inspect, test, service, adjust, align, calibrate, replace) or other maintenance actions (welding, grinding, riveting, straightening, facing, remachining, or resurfacing) to restore serviceability to an item by correcting specific damage, fault, malfunction, or failure in a part, subassembly, module (component or assembly), end item, or system. This function does not include the trial and error replacement of running spare type items such as fuses, lamps, or electron tubes.

j. Overhaul. That maintenance effort (service/action) necessary to restore an item to a completely serviceable/operational condition as prescribed by maintenance standards (i.e., DMWR) in appropriate technical publications. Overhaul is normally the highest degree of maintenance performed by the Army. Overhaul does not normally return an item to like new condition.

k. Rebuild. Consists of those services/actions necessary for the restoration of unserviceable equipment to a like new condition in accordance with original manufacturing standards. Rebuild is the highest degree of materiel maintenance applied to Army equipment. The rebuild operation includes the act of returning to zero those age measurements (hours, miles, etc.) considered in classifying Army equipments/components.

C-3. Column Entries

a. Column 1, Group Number. Column 1 lists

Change 2 C-1

group numbers, the purpose of which is to identify components, assemblies, subassemblies, and modules with the next higher assembly.

b. Column 2, Component/Assembly. Column 2 contains the noun names of components, assemblies, subassemblies, and modules for which maintenance is authorized.

c. Column 3, Maintenance Functions. Column 3 lists the functions to be performed on the item listed in column 2. When items are listed without maintenance functions, it is solely for purpose of having the group numbers in the MAC and RPSTL coincide.

d. Column 4, Maintenance Category. Column 4 specifies, by the listing of a "work time" figure in the appropriate subcolumn(s), the lowest level of maintenance authorized to perform the function listed in column 3. This figure represents the active time required to perform that maintenance function at the indicated category of maintenance. If the number or complexity of the tasks within the listed maintenance function vary at different maintenance categories, appropriate "work time" figures will be shown for each category. The number of task-hours specified by the "work time" figure represents the average time required to restore an item (assembly, subassembly, component, module, end item or system) to a serviceable condition under typical field operating conditions. This time includes preparation time, troubleshooting time, and quality assurance/ quality control time in addition to the time required to perform the specific tasks identified for the maintenance functions authorized in the maintenance allocation chart. Subcolumns of column 4 are as follows:

- C- Operator/Crew
- O- Organizational
- F- Direct Support
- H- General Support
- D- Depot

e. Column 5, Tools and Equipment. Column 5 specifies by code, those common tool sets (not individual tools) and special tools, test, and support equipment required to perform the designated function.

f. Column 6, Remarks. Column 6 contains an alphabetic code which leads to the remark in section IV, Remarks, which is pertinent to the item opposite the particular code.

C-4. Tool and Test Equipment Requirements (Sect. III)

a. Tool or Test Equipment Reference Code. The numbers in this column coincide with the numbers used in the tools and equipment column of the MAC. The numbers indicate the applicable tool or test equipment for the maintenance functions.

b. Maintenance Category. The codes in this column indicate the maintenance category allocated the tool or test equipment.

c. Nomenclature. This column lists the noun name and nomenclature of the tools and test equipment required to perform the maintenance functions.

d. National/NATO Stock Number. This column lists the National/NATO stock number of the specific tool or test equipment.

e. Tool Number. This column lists the manufacturer's part number of the tool followed by the Federal Supply Code for manufacturers (5-digit) in parentheses.

C-5. Remarks (Sect. IV)

a. Reference Code. This code refers to the appropriate item in section II, column 6.

b. Remarks. This column provides the required explanatory information necessary to clarify items appearing in section II.

SECTION II. MAINTENANCE ALLOCATION CHART
FOR

WIND MEASURING SET AN/PMQ-3A

(1) GROUP NUMBER	(2) COMPONENT ASSEMBLY	(3) MAINTENANCE FUNCTION	(4) MAINTENANCE LEVEL					(5) TOOLS AND EQPT.	(6) REMARKS
			C	O	F	H	D		
00	MEASURING SET, WIND AN/PMQ-3A	Inspect Service Service Overhaul	0.2 0.2					4 2,3,5-11	
01	WIND VANE, ANEMOMETER ML-446A/PMQ-3 (A1)	Service Adjust Test Repair Repair Repair Replace Repair		0.5 0.3 0.2 0.5 0.5 0.2		0.5 1.0 0.5		4 4 1 4 3 3	A B C
0101	TRIGGER ASSEMBLY (A12)	Replace			0.5			3	
0102	METER ASSEMBLY, WINDSPEED (A9)	Replace Test Repair		0.5			1.0 1.0	4 6 3	
0103	WIND VANE ML-447A/PMQ-3 (A7)	Replace Repair		0.2			1.0	4 3	
0104	WIND DIAL ASSEMBLY (A11)	Repair Replace				1.0	1.0	3 3	
02	TRANSMITTER, WIND SPEED T-321A/PMQ-3 (A2)	Replace Service Repair Test		0.2 0.3			1.0 2.0	4 3 5-11	
03	CARRYING CASE CY-1067D/PMQ-3 (A13)	Replace Repair		0.2		1.0		3	D
Change 2 C-3									

**SECTION III. TOOL AND TEST EQUIPMENT REQUIREMENTS
FOR**

WIND MEASURING SET AN/PMQ-3A

TOOL OR TEST EQUIPMENT REF CODE	MAINTENANCE CATEGORY	NOMENCLATURE	NATIONAL/ NATO STOCK	TOOL NUMBER NUMBER
1	O	MULTIMETER AN/URM-105	6625-00-581-2036	
2	F, H, D	MULTIMETER TS-352	6625-00-242-5023	
3	F, H, D	TOOL KIT TK-100	5180-00-605-0079	
4	O	TOOL KIT TK-101	5180-00-064-5178	
5	D	VOLTMETER ME-202/U	6625-00-709-0288	
6	D	METER TEST SET TS-682/GSM-1	6625-00-669-0747	
7	D	VACUUM CLEANER, ELECTRIC	7910-00-205-3400	
8	D	COUNTER, ELECTRONIC AN/USM-207	6625-00-911-6368	
9	D	TRANSFORMER, VARIABLE POWER- TF-171/USM	6120-00-503-0632	
10	D	DECADE RESISTOR ZM-16/U	6625-00-669-0266	
11	D	PHONE PLUG	6625-00-500-4508	

SECTION IV. REMARKS
WIND MEASURING SET AN/PMQ-3A

Reference Code	Remarks
A	Repair by replacing wind speed indicator or wind tail assembly.
B	Repair by replacing toggle switch or trigger and switch assembly.
C	Repair by replacing wind speed transmitter or wind dial assembly.
D	Repair of latches, hinges, handles, and padding.
	Change 2 C-5

APPENDIX D

ORGANIZATIONAL, DS, GS, AND DEPOT REPAIR PARTS

Section I. INTRODUCTION

D-1. Scope

This manual contains a list of repair parts required for the performance of organizational maintenance and a list covering the corresponding requirements for direct support, general support, and depot maintenance for Wind Measuring Set AN/PMQ-3A.

Note. No special tools, test, and support equipment are required.

D-2. General

The repair parts list is divided into the following sections:

a. Repair Parts for Organizational Maintenance, Section II. Repair parts authorized for organizational maintenance are included in this section.

b. Repair Parts for Direct Support, General Support and Depot Maintenance Section III. Repair parts authorized for direct support, and depot maintenance are included in this section.

Note. All indexes noted below are cross-referenced to index numbers. The index numbers appear in ascending sequence in column 1 of the repair parts list (para 3a). The index number for the particular item will be the same for the item in all sections of this appendix.

c. Federal Stock Number Cross Reference to Index Number, Section IV. This is a cross reference index of figure number and item number (or reference designation) to index number. The figure numbers are listed in numerical sequence; item numbers and/or reference designations are listed for each figure.

e. Reference Designation Cross Reference to Index Number, Section VI. This is a cross

reference index of reference designations and/ or item numbers to index numbers.

D-3. Explanation of Columns

An explanation of the columns is given below.

a. Source, Maintenance, and Recoverability Codes (SMR) and Index Numbers Column. The first line in this column lists the applicable SMR codes for the part. Listed in ascending order directly below the SMR codes is the index number assigned to the repair part.

(1) *Source code (S).* The selection status and source for the listed item is noted here. Source codes and their explanations are as noted here. Source codes and their explanations are as follows:

<i>Code</i>	<i>Explanation</i>
P--	Applies to repair parts that are stocked in or supplied from the GSA/DSA, or Army supply system, and authorized for use at indicated maintenance categories.
M--	Applies to repair parts that are not procured or stocked but are to be manufactured at indicated maintenance categories.
X2--	Applies to repair parts that are not stocked. The indicated maintenance category requiring such repair parts will attempt to obtain them through cannibalization; if not obtainable through cannibalization, such repair parts will be requisitioned with supporting justification through normal supply channels.

(2) *Maintenance code (M).* The lowest category of maintenance authorized to install the listed item is noted here.

<i>Code</i>	<i>Explanation</i>
O -----	Organizational maintenance
F -----	Direct support maintenance
H -----	General support maintenance
D -----	Depot maintenance

(3) *Recoverability code (R)*. Not used.

Note. When no code is indicated in the recoverability column, the part will be considered expendable.

b. Federal Stock Number Column. The Federal stock number for the item is listed in this column.

c. Description Column. This column includes the Federal item name and any additional description of the item required, the manufacturer's part number (reference number), and the applicable five-digit Federal supply code for manufacturers (para D-5). For subsequent appearances of the same item, the manufacturer's code and part number (reference number) are omitted. The words "same as" followed by the index number assigned to the item when it first appeared in the list will follow the item name, e.g., "RESISTOR, FIXED, COMPOSITION: SAME AS A298". Usable on code column is not used.

d. Unit of Measure Column. The unit used as a basis of measure (e.g., ea, pr, ft, yd, etc.) is indicated in this column.

e. Quantity Incorporated in Unit Column. The quantity of repair parts in an assembly is given in this column. An asterisk indicates that the item may be requisitioned "as required"; however, estimated minimum quantities may be stocked to cover immediate needs.

f. Maintenance Allowances Column.

(1) The maintenance allowance columns are divided into subcolumns. Indicated in each subcolumn opposite the first appearance of the item is the total quantity of items authorized for the number of equipments supported. Subsequent appearances of the same item will have no entry in the allowance columns, but will have a reference in the description column to the first appearance of the item. Items authorized for use as required, but not for initial stockage, are identified with an asterisk (*) in the allowance column.

(2) The quantitative allowances for organizational category of maintenance represents one initial prescribed load for a 15-day period for the number of equipment supported. Units and organizations authorized additional

prescribed loads will multiply the number of prescribed loads authorized by the quantity of repair parts reflected in the appropriate density column to obtain the total quantity of repair parts authorized.

(3) Subsequent changes to organizational allowances will be limited as follows: No change in the range of items is authorized. If additional items are considered necessary, recommendation should be forwarded to Commanding General, U.S. Army Electronics Command, ATTN: AMSEL-ME-NMP-ES, Fort Monmouth, N.J. 07703, for exception or revision to the allowance list. Revisions to the range of items authorized will be made by the USA ECOM National Maintenance Point based upon engineering experience, demand data, or TAERS information.

(4) The quantitative allowances for DS/ GS categories of maintenance will represent initial stockage for a 30-day period for the number of equipment supported.

g. One-Year Allowances Per 100 Equipments /Contingency Planning Purposes Column. Opposite the first appearance of each item, the total quantity required for distribution and contingency planning purposes is indicated. The range of items indicates total quantities of all authorized items required to provide for adequate support of 100 equipments for 1 year.

h. Depot Maintenance Allowance Per 100 Equipments Column. The column indicates the total quantity of each item authorized depot maintenance for 100 equipments. Subsequent appearances of the same item will have no entry in this column, but will have a reference in the description column to the first appearance of the item.

i. Illustrations Column.

(1) *Figure number (a).* The number of the illustration in which the item is shown is indicated in this column.

(2) *Item No. or reference designation (b)* The callout number or reference designation used to reference the item in the illustration appears in this column.

D-4. Location of Repair Parts

a. This manual contains three crossreference indexes (sect. IV, V, and VI), to be used to locate a repair part when either the Federal stock number, reference number (manufacturer's part number), figure number, or reference designation is known. The first column in each cross-reference index is prepared, as applicable, in numerical or alphanumerical sequence. The last column of each cross-reference index lists the index number assigned to the part.

b. Refer to the appropriate cross-reference index (para D-2c, d, e) and note the index number in the last column; then refer to the repair parts list to locate the index number which is listed in ascending order in column 1 of the repair parts list.

D-5. Federal Supply Codes

This paragraph lists the Federal supply code and the associated manufacturer's name.

<i>Code</i>	<i>Explanation</i>
06888-----	L.A. Benson Co., Inc.
07707-----	United Shoe Machinery Corp., Fastener Division
08664-----	The Bristol Co., Bristol Plants Mills
37108-----	Lucas Brothers, Inc.
48834-----	New Departure-Hyatt Bearings Div. of General Motors Corp.
59730-----	The Thomas and Betts Co.
72010-----	Clendenin Bros., Inc.
72962-----	Elastic Stop Nut Corp. of America
80063-----	Army Electronics Command
82205-----	Belfort Instrument Co.
82224-----	John Hassall, Inc.
94143-----	Plastoid Corp.
96906-----	Military Standards

SECTION II. REPAIR PARTS FOR ORGANIZATIONAL MAINTENANCE

(1) SMR CODE INDEX NO.	(2) FEDERAL STOCK NUMBER	(3) DESCRIPTION Reference Number & Mfr Code	(4) UNIT OF MEAS USABLE ON CODE	(5) QTY INC IN UNIT	(6) 15-DAY ORGANIZATIONAL MAINTENANCE ALW				(7) ILLUS- TRATION	
					(a) 1-5	(b) 6-20	(c) 21-50	(d) 51-100	(a) FIG. NO.	(b) ITEM NO. OR REFERENCE DESIGNATION
A000 P-O A001	6660-515-4339	WIND MEASURE SET AN/PMQ-3A: SMD8-367358; 80063 (This item is nonexpendable.)	ea	1	*	*	*	*	A-3	A1
	6660-515-4341	AHER, WIND VANE ML446A/PMQ-3: SM-D-367334; 80063								
P-O	6660-515-4342	WIND SPEED TRANSITTER T-321A/PMQ-B: SM-B-367310; 80063	ea	1	*	*	*	*	2-2	A2
P-O	6660-964-8916	VANE WIND ML-447A/PMQ-3: SM-367294; 80063	ea	1	*	*	*	*	D-1	A7
P-O A159	6660-964-8980	CASE CY-1067D/PP-3: SM-B-367349, 80063	ea	1	*	*	*	*	D-3	A13

Change 2 D-4

SECTION III. REPAIR PARTS FOR DIRECT SUPPORT, GENERAL SUPPORT, AND DEPOT MAINTENANCE

(1) SMR CODE	(2) FEDERAL STOCK NUMBER	(3) DESCRIPTION USABLE ON REFERENCE NUMBER & MFR CODE CODE		(4) UNIT OF MEAS	(5) QTY INC IN UNIT	(6) 30-DAY DS MAINT ALLOWANCE			(7) 30-DAY DS MAINT ALLOWANCE			(8) 1-YR ALW PER EQUIP CMT GCY	(9) DEPOT MAINT ALW PER 100 EQUIP	(10) ILLUS- TRATION (b) ITEM NO. REF. DES.		
						(a)	(b)	(c)	(a)	(b)	(c)			(a)	(b)	
						1-20	21-50	51-100	1-20	21-50	51-100			NO.	NO.	
A000 P-O	6660-515-4339	WIND MEASURE SET AM/PMQ-3A: SM-D-367358; 80063 (This item is nonexpendable.)		ea	1	*	*	*	*	*	*	4	4	A-3	A1	
A001 P-O	6660-515-43,41	AMEMOMETER, WIND VANE ML-446A/PMQ-3; SM-D-367334; 80063		ea	1	*	*	*	*	*	*	4	4	2-2	A2	
A002 M-D	6660-515-4342	WIND SPEED TRANSMITTER T-321A/PMQ-3; SM-B-367310; 80063		ea	1	*	*	*	*	*	*	4	4	D-6	W1	
A003 X2-D	5305-550-5002	HOUSING, GENERATOR: SM-B-367309; 80063		ea	1									D-6	H1	
A004 X2-F		SCREW, MACHINE: 4-40 X 1/4; MS35233-13; 96906		ea	4											H2
A005 X2-D		SOLDER: 60/40; 82205		ea	*											
A006 X2-D		BUSHING ASSEMBLY: SM-B-367276; 80063		ea	1										D-6	A3
A007 X2-D		SCREW, MACHINE, FH: 2-56 x 1/4; MS35242-3; 96906		ea	3										D-6	H3
A008 X2-D		BUSHING PLUG: SM-B-367275; 80063		ea	1										D-6	MP2
A009 X2-D		PIN COUPLING: SM-B-367274; 80063		ea	1											H4
A010 X2-D		PLUG, TELEPHONE: SM-B-367299, 80063		ea	1										D-6	P1
A011 M-D		SCREW, CAP, SOCKET READ: 2-56 X 1/8; 82205		ea	1										D-6	H5
A012 XP-F		WIRE, HOOK UP: SRIR; 94143		ft	1											W1
A013 P-H	SOLDER: SAME AS A005		ea	*											H6	
A014 X2-D	5305-054-6656	RESISTOR, FIXED, COMPOSITION: SM-B-367298; 80063		ea	1				*	*	2	8	6	D-6	R1	
A015 X2-D		SCREW, MACHINE: 6-32 X 5/8; MS35233-31; 96906		ea	1										D-6	H7
A016 X2-D	5310-209-3990	WASHER, LOCK, INTERNAL TOOTH: #6; MS35333-71, 96906		ea	1									D-6	H8	
A017 X2-F	5310-013-1196	WASHER, FLAT, PLAIN: #6; MS35337-60; 96906		ea	1									D-6	H9	
A019 X2-D		SOLDER: SAME AS A005		ea	*											H1
A020 X2-D	5305-058-6833	PILLAR, HEXAGONAL: SM-B-367300, 80063		ea	4									D-6	MP3	
A021 P-H		SCREW, MACHINE: 4-40 X 3/16 in lg.; MS35233-12; 96906		ea	4										D-6	H11
A022 X2-D	5310-550-3715	WASHER, LOCK, INTERNAL TOOTH: #4; MS35333-70; 96906		ea	4									D-6	H12	
A023 X2-D		COIL, RIGHT HAND: SM-B-367307; 80063		ea	1				*	*	2	8	6	D-6	L1	
A024 X2-D	5305-579-3029	SCREW, MACHINE: 2-56 X 1/8 in lg.; MS35233-1; 96906		ea	2									D-6	H13	
A025 X2-F		WASHER, LOCK INTERNAL TOOTH: #2; M335333-69, 96906		ea	2										D-6	H14
A026 M-D	5310-543-4652	WASHER, FIAT, PLAIN: #2; MS35337-58; 96906		ea	2									D-6	H15	
A028		SOLDER: SAM AS A005		ea	*											H16
	WIRE, HOOK UP: SAME AS A012		ft	1											W2	
	BRACKET, COIL: SM-B-367302; 80063		ea	1										D-6	H17	

**SECTION III. REPAIR PARTS FOR DIRECT SUPPORT, GENERAL SUPPORT, AND DEPOT MAINTENANCE
(CONTINUED)**

(1) SMR CODE	(2) FEDERAL STOCK NUMBER	(3) DESCRIPTION USABLE ON REFERENCE NUMBER & MFR CODE CODE		(4) UNIT OF MEAS	(5) QTY INC IN UNIT	(6) 30-DAY DS MAINT ALLOWANCE			(7) 30-DAY DS MAINT ALLOWANCE			(8) 1-YR ALW PER EQUIP CMT GCY	(9) DEPOT MAINT ALW PER 100 EQUIP	(10) ILLUS- TRATION (b) ITEM NO. REF. DES.	
						(a)	(b)	(c)	(a)	(b)	(c)			(a)	(b)
						1-20	21-50	51-100	1-20	21-50	51-100			NO.	NO.
X2-D A029	5950-969-8962	BOBBIN: SM-B-367306; 80063		ea	1										MP4
X2-D A031		EYELET, METALLIC: SE-2 X 1/8 in lg.;		ea	2										H18
X2-D A031	5305-579-3029	EYELET, METALLIC: SE-2 X 3/32 in 14; 07707		ea	2									H19	
P-H H032		COIL, LEFT HAND: SM-367308; 80063		ea	1				*	*	2	8	6	D-6	L2
X2-D A033	5310-543-4652	SCREW, MACHINE: SAME AS A023		ea	2									D-6	H20
X2-D A034		WASHER, LOCK: SAME AS A024		ea	2										D-6
X2-D A035	5310-543-4652	WASHER, FLAT: SAME AS A025		ea	2									D-6	H22
X2-D A036		SOLDER: SAME AS A005		ea	*										
X2-D A037	5310-543-4652	WIRE, HOOK UP: SAME AS A012		ea	1										W3
X2-D A038		BRACKET, COIL: SAME A A028		ea	1										D-6
X2-D A039	5305-579-3029	BOBBIN: SAME AS A029		ea	1										MP5
X2-D A040		EYELET, METALLIC: SAME AS A030		ea	2										
X2-D A041	5310-543-4652	EYELET, METALLIC: SAME AS A031		ea	2										H26
X2-D A042		PLATE, CAGE: S0-8-367296; 80063		ea	1										D-6
X2-D A044	5310-543-4652	SCREW, MACHINE: SAME AS A023		ea	4										H27
X2-D A045		WASHER, LOCK: SAME AS A024		ea	4										
M-D A046	3110-880-2659	CAP, TOP BEARING , RETAINER: SM-B-367358; 80063		ea	1									D-6	MP7
M-D A046A		RETAINER, TOP BEARING: SM-B-367359; 80063		ea	1										D-6
X2-D A046B	3110-880-2659	LOCKWASHER: MS35337-78; 96906		ea	10									D-6	H74
P-H A047		BEARING, PIVOT: 77M0310ZJ5J; 43334		ea	1				*	*	2	13	8	D-7	D-5
X2-D A048	3110-880-2659	SCREW, MACHINE: 2-56 X 5/16; 08661		ea	2									D-5	H33
X2-D A049		ROTOR SHAFT, ASSEMBLY: SM-B-367293; 80063		ea	1										D-6
X2-D A050	3110-880-2659	SCREW, SET: Spline socket; 2-56 X 1/16; 08664		ea	2									D-6	H30
X2-D A051		MAGNET, ROTOR :SM-B-367291; 80563		ea	1										
X2-D A052	3110-880-2659	MAGNET, ROTOR: SM-B-367292; 80063		ea	1										MP10
X2-D A053		ROTOR AND HUD ASSEMBLY: SM-B-367279; 80063		ea	1										
X2-D A054	3110-880-2659	SPACE: SM- B 367277; 80063		ea	1										H31
X2-D A055		SHAFT, ROTOR: SM-B-367278; 80063		ea	1										
X2-D A056	3110-880-2659	ROTOR VANE ASSEMBLY : SM-B-367267; 80063		ea	1									D-6	A5

SECTION III REPAIR PARTS FOR DIRECT SUPPORT, GENERAL SUPPORT, AND DEPOT MAINTENANCE (CONT)

(1) SMR CODE	(2) FEDERAL STOCK NUMBER	(3) DESCRIPTION	(5) QTY INC IN UNIT PACK	(6) QTY INC IN UNIT	(7) 30-DAY DS MAINT ALLOWANCE			(8) 30-DAY GS MAINT ALLOWANCE			(9) 1 YR ALW PER MAINT	(10) DEPOT MAINT	(11) ILLUSTRATIONS	
					(a)	(b)	(c)	(a)	(b)	(c)	EQUIP CNTG	ALW PER 100	(a) FIG	(b) ITEM NO. OR
					1-20	21-50	51-100	1-20	21-50	51-100		EQUIP	NO.	REF. DESIGN.
NO		REFERENCE NUMBER & MFR. CODE												
X2-D		PIN SHOULDER, HEADLESS:	ea	4										MP29
A086		SM-C-367286; 80063												
X2-D		BRACKET, DOUBLE ANGLE:	ea	1										MP30
A087		SM-B-367284; 80063												
X2-D		COLLAR, SHAFT:	ea	2										MP31
A088		SM-B-367287; 80063												
X2-D		SCREW, SET: SAME AS A050	ea	2										H43
A089														
X2-D		HOUSING ASSEMBLY:	ea	1								D-1	A8	
A090		XM-B-367332; 80063												
X2-D		HOUSING BARE:	ea	1										MP32
A091		SM-B-367326; 80063												
X2-D		TUBE, EXTENSION:	ea	1										MP33
A092		SM-B-367325; 80063												
X2-D		HOUSING; WIND MEASURING SET:	ea	1										MP34
A093		SM-B-367324; 80063												
X2-D		PIN, SPRING: 79-028-125-1250;	ea	1										MP35
A094		72962												
X2-D		SIGHT: SM-B-367342; 80063	ea	1								D-2		MP36
A095														
X2-D	5305-550-5002	SCREW, MACHINE: SAME AS A004	ea	2										H44
A096														
X2-D	5310-550-3715	WASBER, LOCK: SAME AS A021	ea	2										H45
A097														
X2-D		PLATE, IDENTIFICATION:	ea	1										MP37
A098		SM-B-367333; 80063												
X2-D	5305-550-5002	SCREW, MACHINE: SAME AS A004	ea	4										H46
A099														
X2-D	5310-550-3715	WASHER, LOCK: SAME AS A021	ea	4										H47
A100														
X2-D		COVER, HOUSING:	ea	1								D-4		MP38
A101		SM-B-367341; 80063												
X2-D		SCREW, MACHINE:	ea	1								D-4		H48
A102		MS3524-29; 96906												
P-F	5975-705-8106	BOOT, DUST AND MOISTURE SEAL:	ea	1	*	*	*	*	*	*	5	3	D-2	MP39
A103		SM-B-367339; 80063												
P-F	5930-296-9636	SWITCH, TOGGLE:	ea	1	*	2	2	*	*	2	12	5	D-2	S1
A104		SM-B-367340; 80063											D-4	
X2-D		BEZEL, INSTRUMENT MOUNTING	ea	1									D-2	MP40
A105		SM-B-367326; 80063												
X2-D	5305-576-5793	SCREW, MACHINE:	ea	3										H49
A106		MS35233-28; 96906												
X2-D		WASHER, NON-METALLIC:	ea	3										H50
A107		SM-B-367343; 80063												
P-F	6660-055-2845	METER ASSEMBLY:	ea	1	*	2	2	*	*	2	12	10	D-2	A9
A108		SM-C-367331; 80063												
X2-D	5310-543-2740	WASHER, LOCK:	ea	2										H51
A109		MS35333-74; 96906												
X2-D		PLATE, RESISTOR, MOUNTING:	ea	1										MP41
A110		SM-B-367330; 80063												
X2-D		RESISTOR, FIXED, COMPOSITION:	ea	1									D-4	R2
A111		SM-C-367331-1; 80063												
X2-D	5305-543-2188	SCREW, MACHINE: 6/32 X 3/4;	ea	1										H52
A112		MS35233-32; 96906												
X2-D	5310-209-3990	WASH EA, LOCK: SAME AS A016	ea	1										H53
X2-D		RESISTOR, FIXED COMPOSITION:	ea	1									D-4	R3
A114		SM-C-367331-2; 80063												

SECTION III REPAIR PARTS FOR DIRECT SUPPORT, GENERAL SUPPORT, AND DEPOT MAINTENANCE (CONT)

(1) SMR CODE	(2) FEDERAL STOCK NUMBER	(3) DESCRIPTION	(5) QTY INC IN UNIT PACK	(6) QTY INC IN UNIT	(7) 30-DAY DS MAINT ALLOWANCE			(8) 30-DAY GS MAINT ALLOWANCE			(9) 1 YR ALW PER EQUIP CMTG	(10) DEPOT MAINT ALW PER 100	(11) ILLUSTRATIONS		
					(a)	(b)	(c)	(a)	(b)	(c)			(a) FIG	(b) ITEM NO. OR REF. DESIGN.	
					INDEX	USABLE ON CODE	1-20	21-50	51-100	1-20	21-50	51-100	EQUIP CMTG	EQUIP	NO.
X2-D A115	5305-543-2188	REFERENCE NUMBER & MFR. CODE SCREW, MACHINE: SAME AS A112	ea	1											HS4
X2-D A116	5310-209-3990	WASHER, LOCK: SAME AS A016	ea	1									D-6		H55
X2-D A117		WIRE, HOOK UP: SR1R (White); 94143	ft	3									D-4		W4
X2-D A118		TERMINAL LUG: RA18-14; 59730	ea	2									D-4		E1
X2-D A119		SOLDER: SAME AS A005	ea	*											H56
X2-D A120		JACK, ASSEMBLY: SM-B-367323; 80063	ea	1									D-1		A10
X2-D A121	5305-550-5002	SCREW, MACHINE: SAME AS A004	ea	3									D-6		H57
X2-D A122	5310-550-3715	WASHER, LOCK: SAME AS A021	ea	3											H58
X2-D A123		JACK, TELEPHONE: BM-B-367320; 80063	ea	1									D-6		J1
X2-D A124		BUSHING, JACK: SM-B-367321; 80063	ea	1											MP42
X2-D A125		CONTACT, ELECTRICAL: SM-B-367322; 80063	ea	1											E2
X2-D A126		SCREW, CAP, SOCKET HEAD: SAME AS A011	ea	1									D-6		H59
X2-D A127		WIRE, HOOK UP: SAME AS A117	ft	2									D-4		W5
X2-D A128		TERMINAL, LUG: SAME AS A118	ea	1											E3
X2-D A129		SOLDER: SAME AS A005	ea	*											H60
X2-D A130		SHAFT, VERTICAL: SM-B-367338; 80063	ea	1									D-4		MP43
X2-D A131		SCREW, CAP, SOCKET HEAD: SAME AS A011	ea	1									D-6		H61
X2-D A132		SCREW, MACHINE: 1-40 X 1/8; 08664	ea	2									D-4		H62
X2-D A133		PIN BRAKE: SM-C-367347; 80063	ea	1									D-1		MP44
X2-D A134		BUSHIN, ROD: SM-C-367346; 80063	ea	1											MP45
X2-D A135		RING, VANE: SM-C-367344; 80063	ea	1									D-1		MP46
X2-D A136		HUB WIND VANE: SM-C-367348; 80063	ea	1									D-1		MP47
X2-D A137		NOSE WIND VANE: SM-C-367345; 80063	ea	1									D-1		MP48
X2-D A138		NUT, HEX: 8-32; MS35649-84; 96906	ea	1									D-1		H63
P-H A139	3110-056-0434	BALL, BEARING: 440C; 43334	ea	30				4	3	3	118	120	D-1		MP49
P-H A140	6660-055-2844	WIND DIAL ASSEMBLY: SM-C-367337; 80063	ea	1				*	*	*	4	3	D-1		A11
X2-D A141		SCREW, MACHINE, FLAT: 1/4 X 4-40; MS35249-20; 96906	ea	3											H64
X2-D A142		HUB, DIAL: SM-C-367336; 80063	ea	1				-					D-1		MP50
X2-D A143		DIAL, SCALE: SM-C-367335; 80063	ea	1									D-1		MP51

SECTION III REPAIR PARTS FOR DIRECT SUPPORT, GENERAL SUPPORT, AND DEPOT MAINTENANCE (CONT)

(1) SMR CODE	(2) FEDERAL STOCK NUMBER	(3) DESCRIPTION	(5) QTY INC IN UNIT PACK	(6) QTY INC IN UNIT	(7) 30-DAY DS MAINT ALLOWANCE			(8) 30-DAY GS MAINT ALLOWANCE			(9) 1 YR ALW PER EQUIP CNTG	(10) DEPOT MAINT ALW PER 100	(11) ILLUSTRATIONS	
					(a)	(b)	(c)	(a)	(b)	(c)			(a) FIG	(b) ITEM NO. OR REF. DESIGN.
					INDEX	USABLE ON CODE								
P-F A144	6660-055-2846	TRIGGER ASSEMBLY: SM-C-367319; 80063	ea	1	*	*	*	*	*	*	4	4	D-1	A12
X2-D A145	5305-543-2188	SCREW, MACHINE: SAME AS A112	ea	3										H65
X2-D A146	5310-209-3990	WASHER, LOCK: SAME AS A016	ea	3										H66
X2-D A147		TRIGGER, VANE: SB-B-367314; 80063	ea	1									D-4	MP52
X2-D A148		SPRING, TRIGGER, RETURN: SM-B-367316; 80063	ea	1									D-4	MP53
X2-D A149		SHAST, TRIGGER: SM-B-367318; 80063	ea	1									D-4	MP54
X2-D A150		PLUNCER, VANE LOCK: SM-B-367315; 80063	ea	1									D-4	MP55
X2-D A151		SPRING, VANE LOCK: SM-B-367317; 80063	ea	1									D-4	MP56
X2-D A152		RING, RETAINER: SM-B-367319-1; 80063	ea											MP57
X2-D A153		PLATE, ASSEMBLY: SM-B-367313; 80063	ea											MP58
X2-D A154		PLATE, SWITCH: SM-B-367311; 80063	ea	1										MP59
X2-D A155		RIVET, SOLID: 1/8 dia X 3/8 lg; 82224	ea	2										H67
X2-D A156		RIVET, SOLID: 3/32 dia X 1/4 lg; 72010	ea	1										H68
X2-D A157		RACKET, PLUNGER: SM-B-367312; 80063	ea	1										MP60
X2-D A158		BRACKET, ANGLE: SM-B-367305; 81163	ea	1										MP61
P-O A159	6660-964-8980	CASE CY-1067D/PMQ-3: SM-B-367349; 80063	ea	1	*	*	*	*	*		4	4	D-3	A13
M-D A160		CASE, BARE: SM-B-367350; 80063	ea	1									D-3	MP62
M-D A161		CASE, INSERT, TOP: SM-B-367351; 80063	ea	1									D-3	MP63
M-D A162		CASE, INSERT, BOTTOM: SM-B-367352; 80063	ea	1									D-3	MP64
X2-D A163		HINGE, CASE: SM-B-367354; 80063	ea	2										MP65
X2-D A164		HINGE BUTT: SM-B-367353; 80063	ea	2										MP66
X2-D A165		RIVET, TUBULAR: 3/16 dia X 1/4 lg; 82205	ea	8										H69
X2-D A166		HANDLE, SURFACE: SM-B-367355; 80063	ea	1										MP67
X2-D A167		RIVET, TUBULAR SAME AS A165	ea	5										H70
M-D A168		PLATE, IDENTIFICATION: SM-B-367356; 80063	ea	1										MP68
M-D A169		PLATE, IDENTIFICATION: SM-B-367357; 80063	ea	1										MP69
X2-D A170	5305-058-6833	SCREW, MACHINE: SAME AS A020	ea	4										H71
X2-D A171	5310-550-3715	WASHER, LOCK: SAME AS A021	ea	4										H72
X2-D A172		NUT HEX #4: MS35649-44;	ea	4										H73

SECTION III REPAIR PARTS FOR DIRECT SUPPORT, GENERAL SUPPORT, AND DEPOT MAINTENANCE (CONT)

(1) SMR CODE	(2) FEDERAL STOCK NUMBER	(3) DESCRIPTION	(5) QTY INC IN UNIT PACK	(6) QTY INC IN UNIT	(7) 30-DAY DS MAINT ALLOWANCE			(8) 30-DAY GS MAINT ALLOWANCE			(9) 1 YR ALW PER EQUIP CNTG CY	(10) DEPOT MAINT ALW PER 100 EQUIP	(11) ILLUSTRATIONS	
					(a)	(b)	(c)	(a)	(b)	(c)			(a)	(b)
					FIG	NO.	REF.	DESIGN.	OR	ITEM NO.			OR	REF.
P-O A173	6660-515-4342	REFERENCE NUMBER & MFR. CODE WIND SPEED TRANSMITTER T-321A/PMQ,-3 SAME AS A002	ea	1	1-20	21-50	51-100	1-20	21-50	51-100		D-2	A2	
P-O A174	6660-964-8916	VANE WIND ML-447A/PMQ-3: Same as a080	ea	1								D-1	A7	

**SECTION IV. INDEX-FEDERAL STOCK NUMBER CROSS REFERENCE
TO INDEX NUMBER**

FEDERAL STOCK NUMBER	INDEX NO.	REF NUMBER	INDEX NO.	REF NUMBER	INDEX NO.
3110-056-0434	1A139	RA18-14	A118	SM-B-367313	A153
3110-880-2659	A047	SE-2x1/8 in.lg	A030	SM-B-367314	A147
5305-054-6658	A015				
5305-058-6833	A020	SE-2x3/32 in. lg	A031	SM-B-367315	A150
5305-543-2188	A112	SM-B-367259	A060	SM-B-367316	A148
5305-550-5002	A004	SM-B-367260	A059	SM-B-367317	A151
		SM-B-367261	A058	SM-B-367318	A149
5305-576-5793	A106	SM-B-367263	A062	SM-B-367319-1	A152
5305-579-3029	A023	SM-B-367264	A061	SM-B-367320	A123
5310-013-1196	A017	SM-B-367265	A057	SM-B-367321	A124
5310-209-3990	A016	SM-B-367266	A064	SM-B-367322	A125
5310-271-4641	A069	SM-B-367267	A056	SM-B-367323	A120
5310-543-2740	A109	SM-B-367274	A009	SM-B-367324	A093
5310-543-4652	A024	SM-B-367275	A008	SM-B-367325	A092
5310-550-3715	A021	SM-B-367276	A006	SM-B-367326	A091
5930-296-9636	A104	SM-B-367277	A054	SM-B-367328	A105
5950-969-8961	A022	SM-B-367278	A055	SM-B-367330	A110
5950-969-8962	A032	SM-B-367279	A053	SM-B-367331-2	A114
		SM-B-367283	A082	SM-B-367332	A090
6660-055-2844	A140	SM-E-367284	A087	SM-B-367333	A098
6660-055-2845	A108	SM-B-367287	A088	SM-B-367338	A130
6660-055-2846	A144	SM-B-367291	A051	SM-B-367341	A101
6660-515-4339	A000	SM-B-367292	A052	SM-B-367342	A095
6660-515-4341	A001	SM-B-367293	A049	SM-B-367343	A107
6660-515-4342	A002	SM-B-367296	A042	SM-B-367350	A160
6660-964-8916	A080	SM-B-367297	A066	SM-B-367351	A161
6660-964-8980	A159	SM-B-367298	A014	SM-B-367352	A162
		SM-B-367299	A010	SM-B-367353	A164
		SM-B-367300	A019	SM-B-367354	A163
		SM-B-367302	A028	SM-B-367355	A166
		SM-B-367304	A065	SM-B-367356	A168
		SM-B-367305	A158	SM-B-3673,7	A169
		SM-B-367306	A029	SM-B-367358	A046
		SM-B-367309	A003	SM-B-367359	A046A
		SM-B-367311	A154	SM-C-367273	A079
		SM-B-367312	A157	SM-C-367280	A076

**SECTION IV INDEX-FEDERAL STOCK NUMBER CROSS REFERENCE
TO INDEX NUMBER (CONTINUED)**

REF NUMBER	INDEX NO.	FEDERAK STOCK NUMBER	INDEX NO.	FEDERAL STOCK NUMBER	INDEX NO.
SM-C-367285	A085				
SM-C-367286	A086				
SM-C-367288	A084				
SM-C-367301	A075				
SM-C-367331-1	A111				
S-C-367335	A143				
SM-C-367336	A142				
SM-C-367344	A135				
SM-C-367345	A137				
SM-C-367346	A134				
SM-C-367347	A133				
SM-C-367348	A136				
SM-D-367295	A072				
SRIR	A012				
SRIR (white)	A117				
1-72x1/8	A067				
1/8 dia x 3/8 1B	A155				
24	A070				
2-56x1/16	A050				
2-56x1/8	A001				
2-56x3/16	A074				
2-56x5/16	A048				
3/16 dia x 1/4 Lg	A165				
3/32 dia x 1/4 Lg	A156				
4-40x1/8	A132				
60/40	A005				
79-028-125-1250	A094				

**SECTION V. INDEX-FIGURE AND ITEM NUMBER CROSS REFERENCE
TO INDEX NUMBER**

FIG. NO.	ITEM NO. OR REFERENCE DESIGNATION	INDEX NO.	FIG. NO.	ITEM NO. OR REFERENCE DESIGNATION	INDEX NO.
A-3	A1	A001		H14	A024
D-1	A7	A080		H15	A025
	A8	A090		H17	A028
	A10	A120		H20	A033
	A11	A140		H21	A034
	A12	A144		H22	A035
	H63	A138		H24	A038
	MP26	A081		H30	A050
	MP44	A133		H39	A077
	MP46	A135		H40	A078
	MP47	A136		H41	A081
	MP48	A137		H55	A116
	MP49	A139		H57	A121
	MP50	A142		H59	A126
	MP51	A143		H61	A131
D-2	A2	A173		H74	A046B
	A9	A1008		J1	A123
	MP36	A095		L1	A022
	MP39	A103		L2	A032
	MP40	A105		MP1	A003
	S1	A104		MP2	A008
D-3	A13	A159		MP3	A019
	MP62	A160		MP6	A042
	MP63	A161		MP7	A046
	MP64	A162		MP21	A066
D-4	E1	A118	D-7	MP25	A076
	H48	A102		MP70	A046A
	H62	A132		P1	A010
	MP38	A101		R1	A014
	MP43	A130			
	MP52	A147	2-2	H74	A046B
	MP53	A148		A2	A002
	MP54	A149			
	MP55	A150			
	MP56	A151			
	R2	A111			
	R3	A114			
	S1	A104			
	W4	A117			
	W5	A127			
D-5	H33	A048			
	MP8	A047			
	MP13	A057			
	MP20	A065			
	MP22	A071			
	MP23	A072			
	MP24	A075			
D-6	A3	A006			
	A4	A049			
	A5	A056			
	A6	A079			
	H1	A004			
	H3	A007			
	H5	A011			
	H7	A015			
	H8	A016			
	H9	A017			
	H11	A020			
	H12	A021			
	H13	A023			

**SECTION VI. INDEX-REFERENCE DESIGNATION CROSS REFERENCE
TO INDEX NUMBER**

REFERENCE DESIGNATION	INDEX NO.	REFERENCE DESIGNATION	INDEX NO.	REFERENCE DESIGNATION	INDEX NO.
A1	A001	H21	A034	H58	A122
A2	A002	H22	A035	H59	A126
A2	A173	H23	A036	H60	A129
A3	A006	H24	A038	H61	A131
A4	A049	H25	A040	H62	A132
A5	A056	H26	A041	H63	A138
A6	A079	H27	A044	H64	A141
A7	A080	H28	A045	H65	A145
A8	A090	H29	A067	H66	A146
A9	A108	H30	A050	H67	A155
A10	A120	H31	A054	H68	A156
A11	A140	H32	A064	H69	A165
A12	A144	H33	A048	H70	A167
A13	A159	H34	A068	H71	A170
E1	A118	H35	A069	H72	A171
E2	A125	H36	A070	H73	A172
E3	A128	H37	A073	H74	A046B
H1	A004	H38	A074	H74	A046B
H2	A005	H39	A077	J1	A123
H3	A007	H40	A078	L1	A022
H4	A009	H41	A081	L2	A032
H5	A011	H42	A083	MP1	A003
H6	A013	H43	A089	MP2	A008
H7	A015	H44	A096	MP3	A019
H8	A016	H45	A097	MP4	A029
H9	A017	H46	A099	MP5	A039
H10	A018	H47	A100	MP6	A042
H11	A020	H48	A102	MP7	A046
H12	A021	H49	A106	MP8	A047
H13	A023	H50	A107	MP9	A051
H14	A024	H51	A109	MP10	A052
H15	A025	H52	A112	MP11	A053
H16	A026	H53	A113	MP12	A055
H17	A028	H54	A115	MP13	A057
H18	A030	H55	A116	MP14	A058
H19	A031	H56	A119	MP15	A059
H20	A033	H57	A121	MP16	A060

**SECTION VI. INDEX-REFERENCE DESIGNATION CROSS REFERENCE
TO INDEX NUMBER**

REFERENCE DESIGNATION	INDEX NO.	REFERENCE DESIGNATION	INDEX NO.	REFERENCE DESIGNATION	INDEX NO.
MP17	A061	MP54	A149		
MP18	A062	MP55	A150		
MP19	A063	MP56	A151		
MP20	A065	MP57	A152		
MP21	A066	MP58	A153		
MP22	A071	MP59	A154		
MP23	A072	MP60	A157		
MP24	A075	MP61	A158		
MP25	A076	MP62	A160		
MP26	A082	MP63	A161		
MP27	A084	MP64	A162		
MP28	A085	MP65	A163		
MP29	A086	MP66	A164		
MP30	A087	MP67	A166		
MP31	A088	MP68	A168		
MP32	A091	MP69	A169		
MP33	A092	MP70	A046A		
MP34	A093	P1	A010		
MP35	A094	R1	A014		
MP36	A095	R2	A111		
MP37	A098	R3	A114		
MP38	A101	S1	A104		
MP39	A103	S1	A104		
MP40	A105	W1	A012		
MP41	A110	W2	A027		
MP42	A124	W3	A037		
MP43	A130	W4	A117		
MP44	A133	W5	A127		
MP45	A134				
MP46	A135				
MP47	A136				
MP48	A137				
MP49	A139				
MP50	A142				
MP51	A143				
MP52	A147				
MP53	A148				

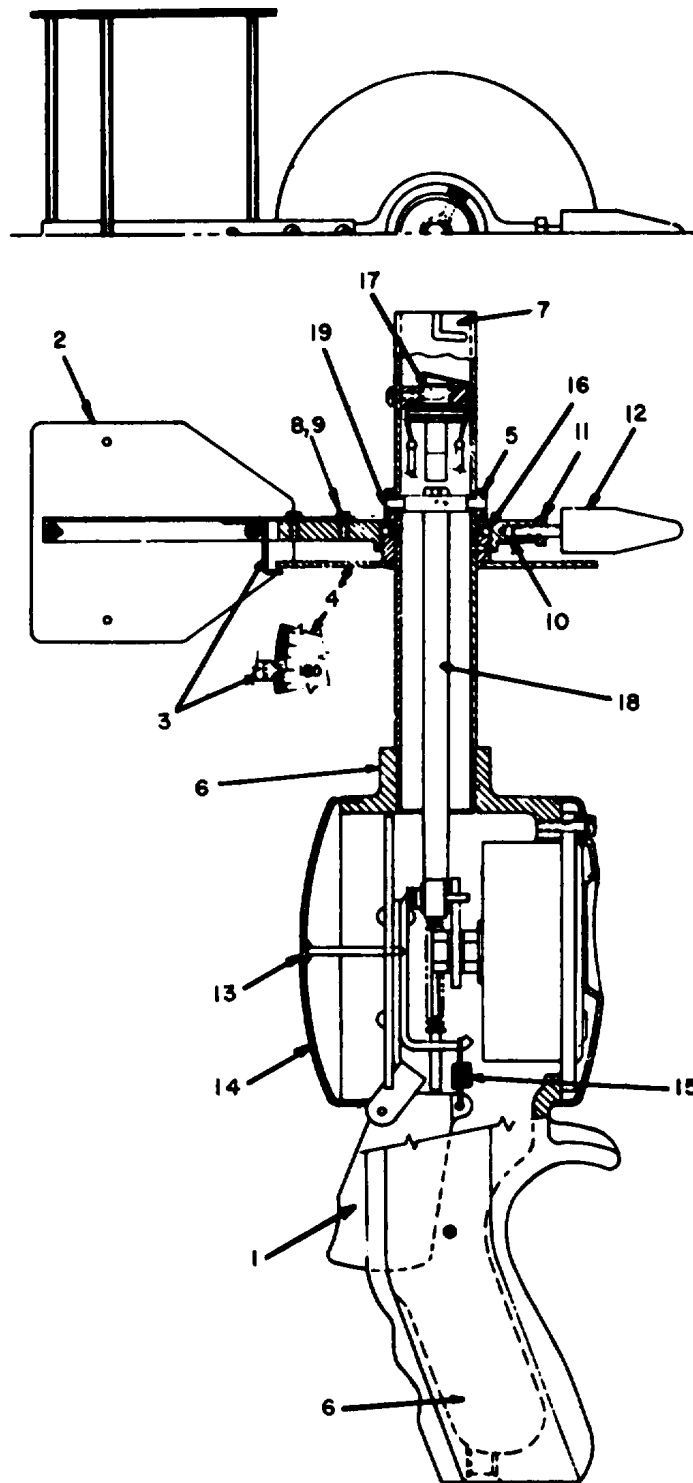

TM6660-232-15-9

- | | | | |
|--------------------------------|-------------------------|------------------------------|------------------------------------|
| 1 Trigger assembly A12 | 5 Ring, vane brake MP46 | 10 Hub, wind vane MP47 | 15 Spring, trigger reclaiming MP53 |
| 2 Wind vane assembly A7 | 6 Body assembly MP32 | 11 Nut, hex. 8-32, H63 | 16 Bearing, ball MP49 |
| 3 Pointer index MP26 | 7 Housing assembly A8 | 12 Nose, vane MP48 | 17 Jack assembly A10 |
| 4 Dial, wind vane assembly A11 | 8 Screw H41 | 13 Screw, 4-40 x 1 5/16, H48 | 18 Shaft, vertical MP43 |
| | 9 Lockwasher H12 | 14 Cover, housing MP38 | 19 Pin, brake release MP44 |

Figure D-1. Wind Measuring Set AN/PMQ-3A, sectional view.

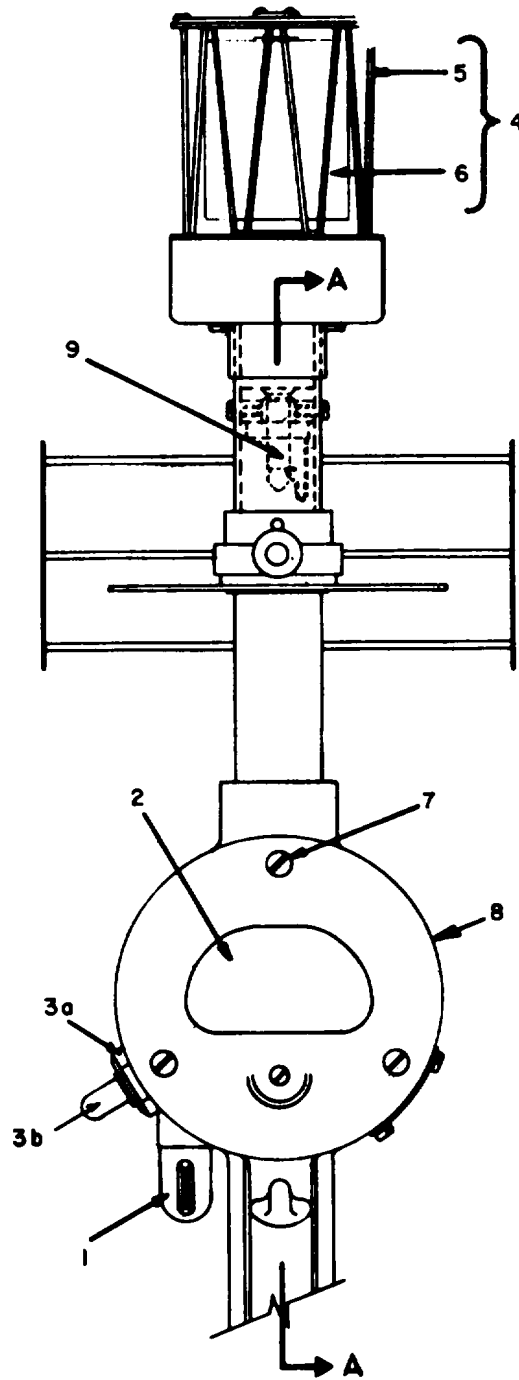

TM 6660-232-15-10

- | | | |
|----------------------|-----------------------------|-------------------------------|
| 1 Sight MP36 | 4 Wind speed transmitter A2 | 7 Screw 6-32 x 3/4 Bd. Hd H52 |
| 2 Meter assembly A9 | 5 Cage, transmitter A6 | 8 Bezel, housing MP40 |
| 3a Switch, toggle S1 | 6 Rotor, vane assembly A5 | 9 Plug (male) P1 |
| 3b Boot, switch MP39 | | |

Figure D-2. Wind measuring set AN/PMQ-A
(front sectional view.)

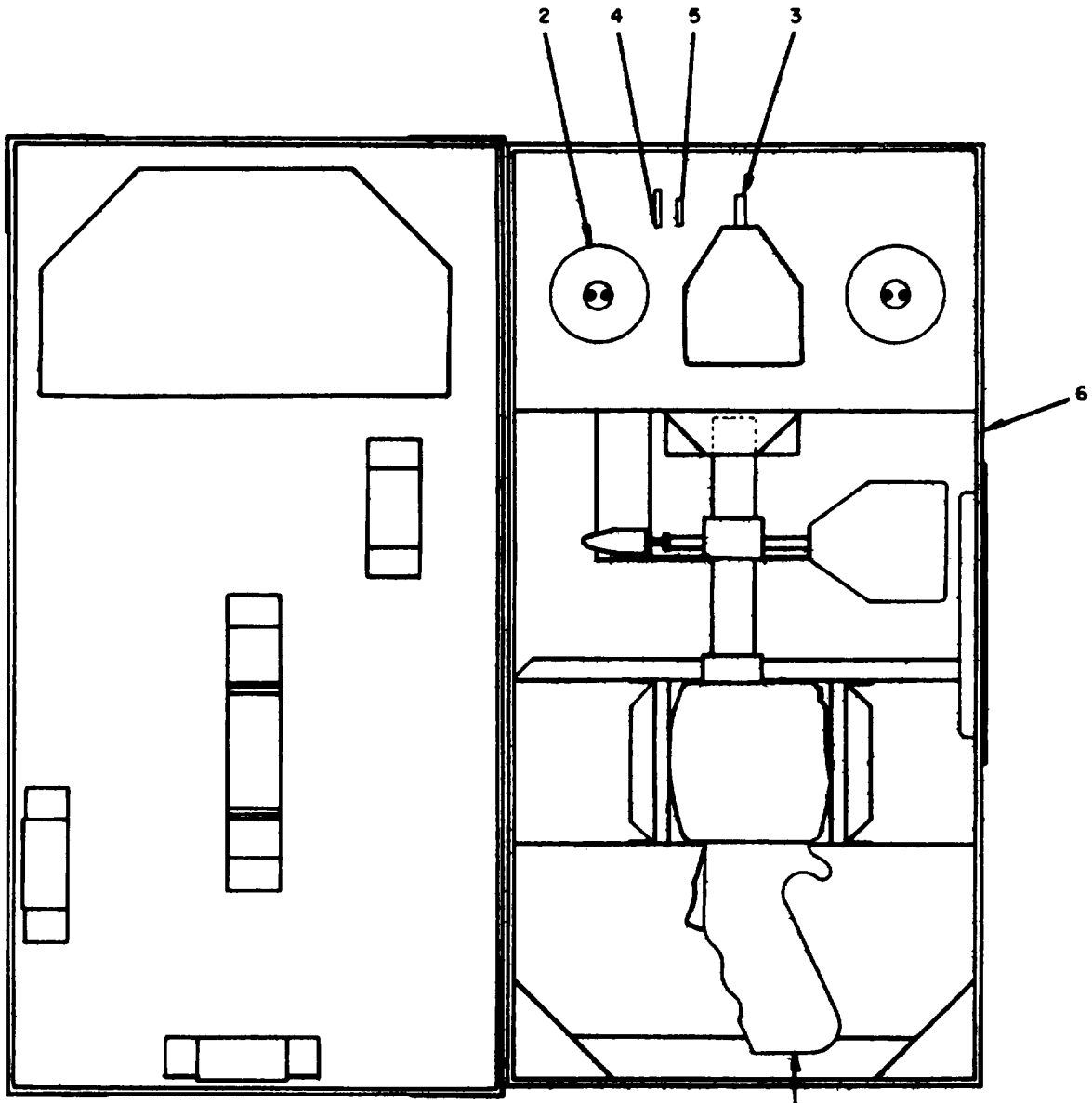

TM6660-232-15-11

- | | | | |
|---|---------------------------------------|---|-----------------------------|
| 1 | Wind direction set (less transmitter) | 4 | No. 2 Bristol spline wrench |
| 2 | Wind speed transmitter (spare) A2 | 5 | No. 4 Bristol spline wrench |
| 3 | Wind direction vane (spare) A7 | 6 | Case assembly A13 |

Figure D-3. Wind measuring set AN/PMQ-A, with case.

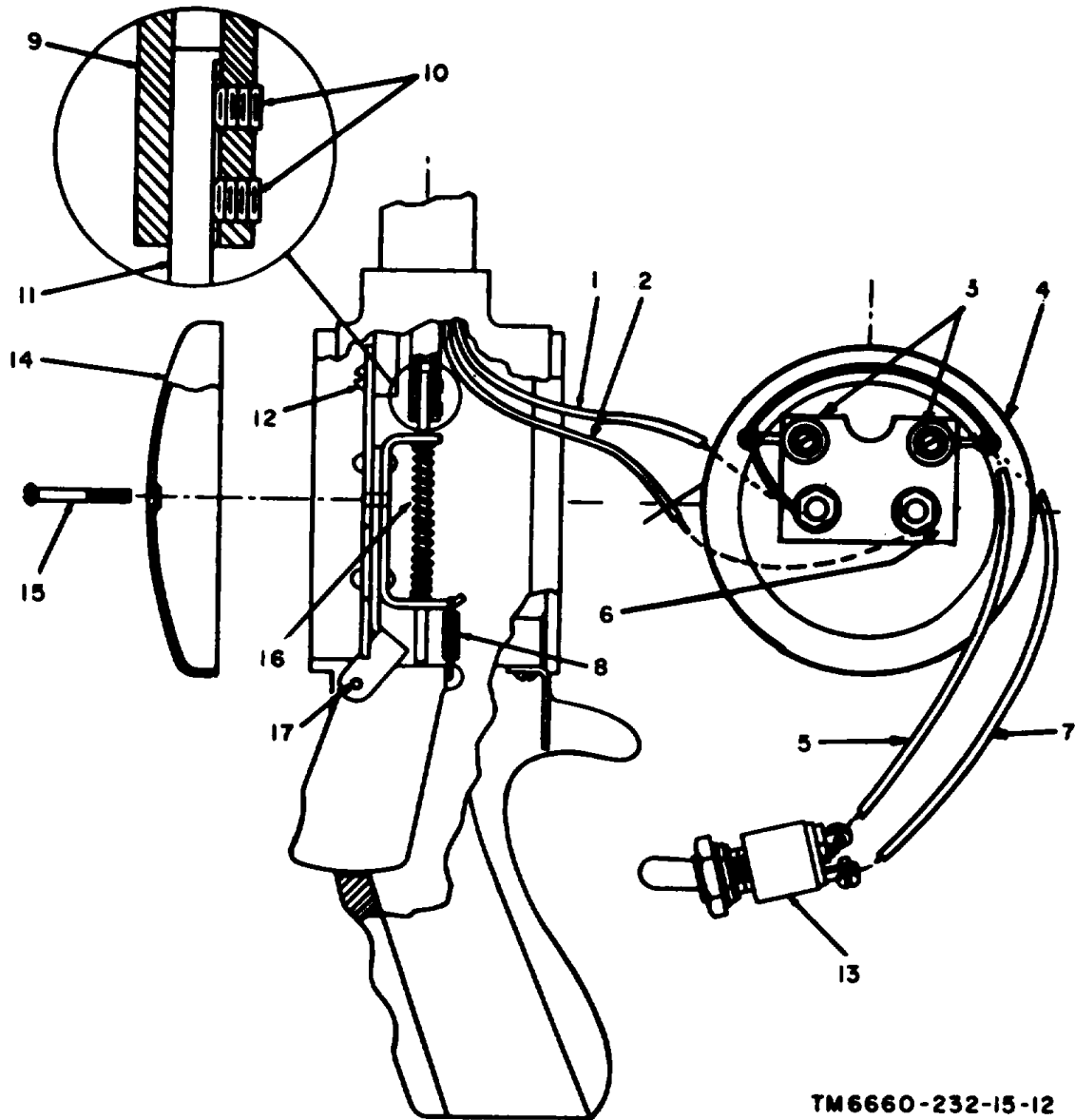

TM6660-232-15-12

- | | | |
|-----------------------|----------------------------------|------------------------|
| 1 Transmitter wire W4 | 7 Switch wire W5 | 13 Switch S1 |
| 2 Transmitter wire W4 | 8 Trigger reclaiming spring MP53 | 14 Cover MP38 |
| 3 Resistor (R2) (R3) | 9 Vertical rod MP43 | 15 Screw H48 |
| 4 Speed indicator A9 | 10 Setscrew H62 | 16 Spring MP56 |
| 5 Switch wire W5 | 11 Plunger MP55 | 17 Shaft, trigger MP54 |
| 6 Resistor board MP41 | 12 Screw H61 | |

Figure D-4. Partial disassembly anemometer wind-vane.

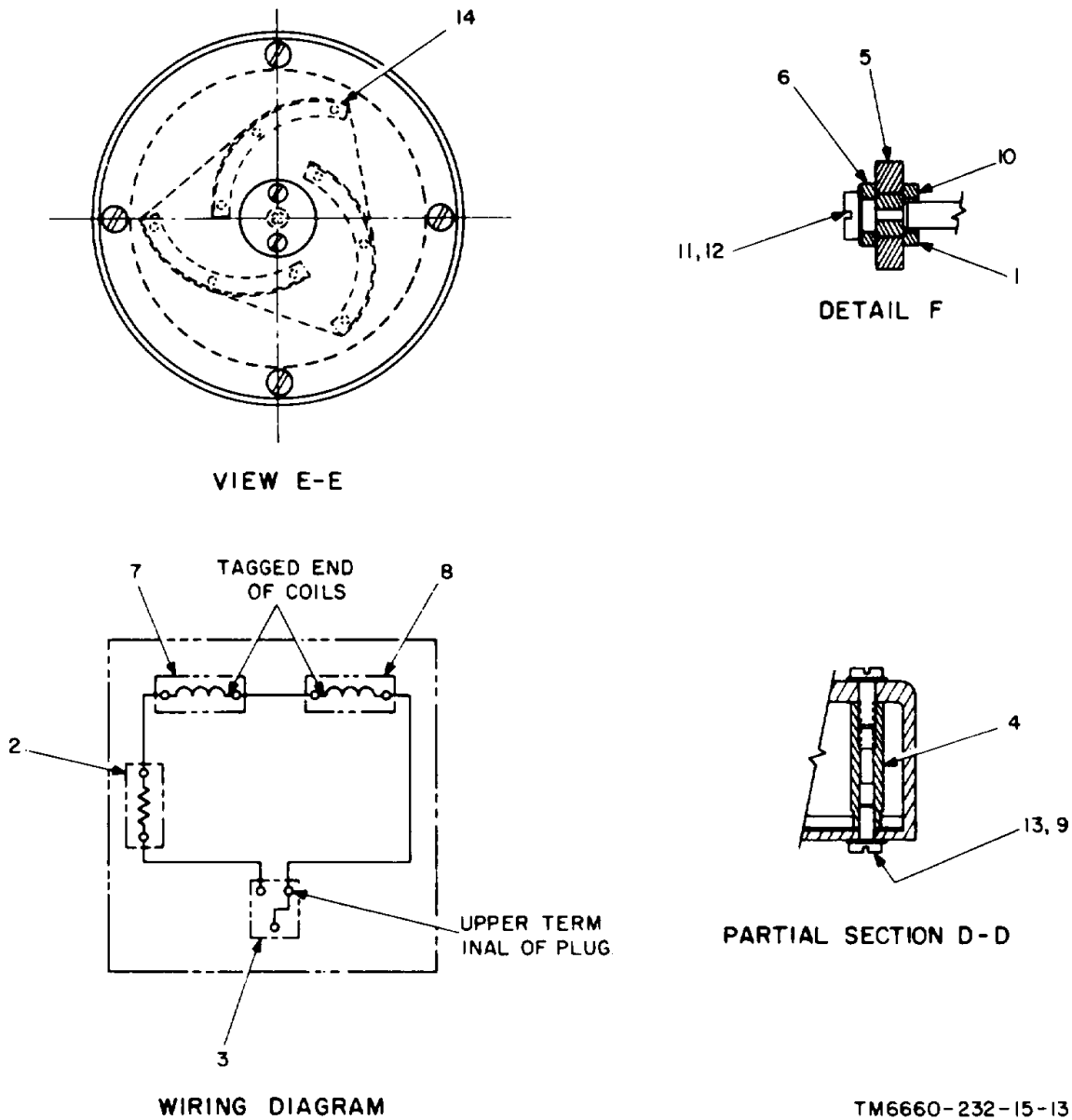

TM6660-232-15-13

- 1 Plate, retainer bearing MP23
- 2 Resistor, fixed R1
- 3 Plug, telephone P1
- 4 Pillar, generator mtg. MP3
- 5 Plate, retainer bearing MP24
- 6 Retainer, lower bearing MP20
- 7 Generator coil, right-hand L1

- 8 Generator coil, left-hand L2
- 9 Washer, lock H74
- 10 Bearing, pivot MP8
- 11 Washer, lock H12
- 12 Screw, machine H33
- 13 Screw, machine H11
- 14 Segment, vane MP13

Figure D-5. Wind measuring set, T-21A/PMQ- (sectional view-).

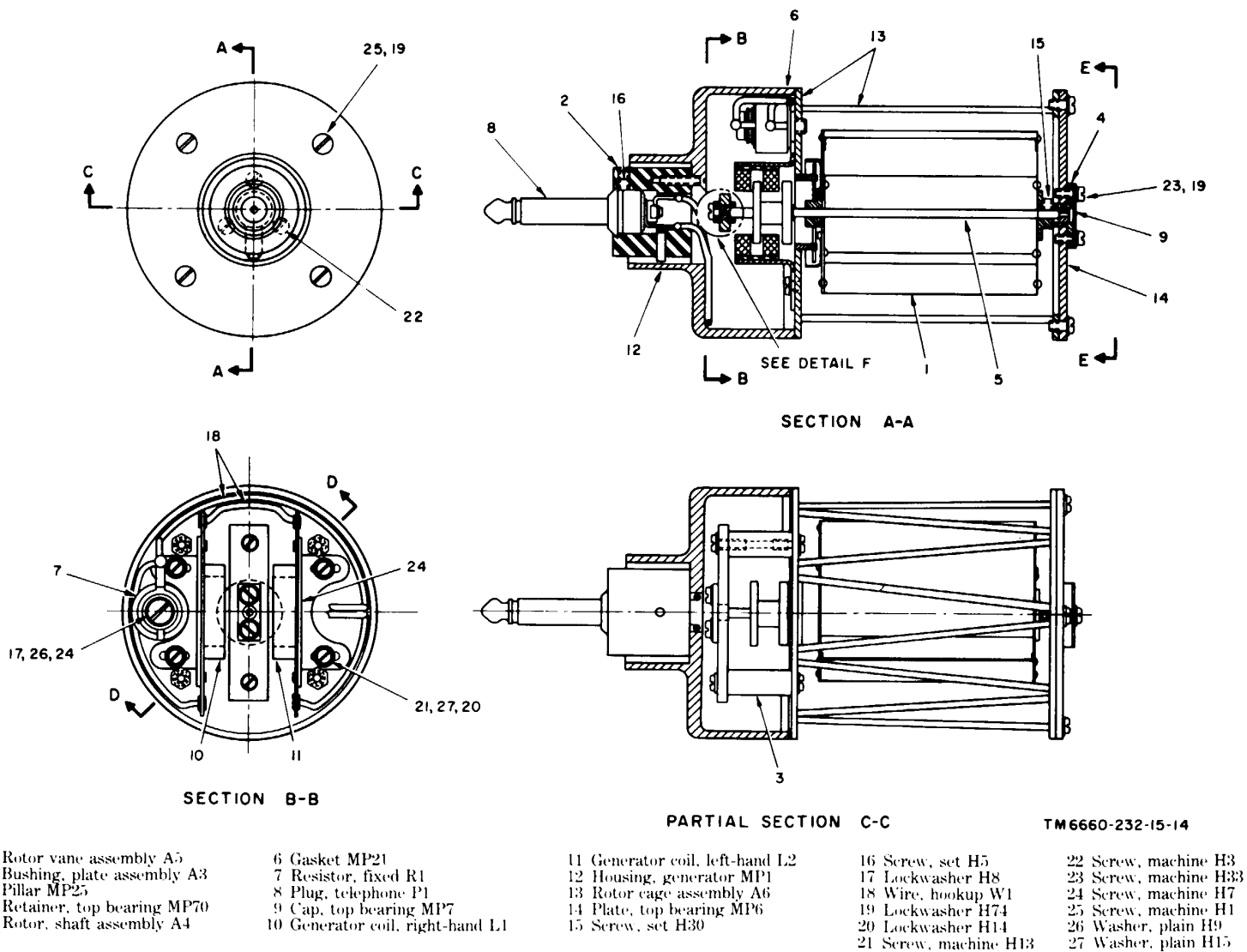

Figure D-6. Wind speed transmitter, T-321A/PMQ-3 (sectional view).

Change 2 D-22

INDEX

	Paragraph	Page		Paragraph	Page
Arctic climate operation	2-8	2-5	Repair of windspeed transmitter	63	6-1
Authority for demolition	8-3	8-1	Scope	6-1	6-1
Checking unpacked equipment	2-2	2-1	Tools, materials, and test equip-		
Circuit functions:			ment required	6-2	6-1
General.....	4-13	4-4	Indexes of publications	1-2	1-1
Transmitter	4-14	4-4	Installation and operating instruc-		
Wind direction	4-15	4-4	tion:		
Cleaning.....	3-6	3-2	Arctic operation.....	2-8	2-5
Common names	1-7	1-2	Checking unpacked equipment	2-2	2-1
Components and dimensions	1-6	1-2	Desert operation	2-9	2-5
Demolition of materiel to prevent			Installing transmitter	2-4	2-3
enemy use:.....			Operating under unusual condi-		
Authority for demolition	8-3	8-1	tions	2-8,2-10	2-5
Disassembly of equipment.....	8-1	8-1	Operational procedure	2-7	2-5
Methods of destruction	8-4	8-1	Principles of operation	2-6	2-4
Depot maintenance:.....			Removing and replacing equip-		
Scope	7-1	7-1	ment in case	2-3	2-1
Standards	7-3	7-1	Siting.....		2-5
2-3					
Tools, materials, and test equip ..			Tropical operation	2-9	2-5
ment required	7-2	7-1	Lubrication		4-5
4-1					
Windspeed transmitter	7-4	7-1	Maintenance:		
Wind vane, anemometer	7-5	7-1	Depot:		
Description and data:			Scope	7-1	7-1
Components of wind measuring ..			Standards	7-3	7-1
set	1-6	1-2	Tools, materials, and test		
Description of components	1-9	1-2	equipment required	7-2	7-1
Description of wind measuring			Windspeed transmitter	7-4	7-1
set	1-8	1-2	Wind vane, anemometer	7-5	7-1
Purpose and use	1-4	1-1	Direct support:		
Technical characteristics	1-5	1-2	Removal and replacement of		
Desert climate operation	2-10	2-6	toggle switch	5-4	5-3
Direct support maintenance:			Removal and replacement		
Direct support repair organiza-		of trigger switch assem-		
tional procedures.....	5-3	5-1	bly	5-5	5-3
Removal and replacement of			Scope.....	5-1	5-1
toggle switch	5-4	5-3	Tools, materials, and test		
Removal and replacement of			equipment required	5-2	5-1
trigger switch assembly	5-5	5-3	Troubleshooting procedures-	5-3	5-1
Scope	5-1	5-1			
Tools, materials, and test equip-			General support:		
ment required	5-2	5-1	Repair and adjustment of		
Disassembly of wind measuring set.....	8-1		trigger assembly	6-4	6-1
Forms and records.....	1-2	1-1	Removal and replacement		
Function of wind direction indicator ..	4-4		of wind direction dial		
Functions of transmitter	4-14	4-4	assembly	6-5	6-2
General support:			Repair of windspeed trans-		
Removal and replacement of			mitter	6-3	6-1
wind dial assembly	6-5	6-2	Scope	6-1	6-1
Repair and adjustment of trig-			Tools, materials, and test		
ger assembly	6-4	6-1	equipment required	6-2	6-1

	Paragraph	Page		Paragraph	Page
Maintenance-Continued			Scope	4-1	4-1
Operator's maintenance:			Tools, materials, and test equip- ment required.....	4-2	4-1
Cleaning	3-6	3-2	Purpose and use	1-3	1-1
Maintenance.....	3-3	3-1	Removal and replacement:		
Preventive maintenance.....			Equipment in case	2-3	2-1
checks and services			Toggle switch.....	5-4	5-3
chart.....	3-5	3-2	Trigger switch assembly	5-5	5-3
Preventive maintenance.....			Windspeed indicator	4-1	4-1
checks and services			Wind vane tail assembly	4-12	4-3
periods	3-4	3-1			
Tools, materials, and test equipment required.....	3-2	3-1	Repair and adjustment of trigger assembly	6-4	6-1
Troubleshooting chart	3-7	3-2	Repair procedures for direct support.....	5-1	
.....			Replacement of wind dial assembly.....	6-2	
Organizational maintenance:			Scope:		
General.....	4-9	4-3	Depot maintenance	7-1	7-1
General functions	4-13	4-4	Direct support.....	5-1	5-1
Lubrication.....	4-5	4-1	General support	6-1	6-1
Monthly preventive maintenance.....	4-1		Of manual	1-1	1-1
Monthly preventive maintenance checks and services chart	4-8	4-2	Operator's maintenance	3-1	3-1
Quarterly preventive maintenance	4-7	4-2	Organization maintenance.....	4-1	4-1
Quarterly preventive maintenance checks	4-8	4-2	Service upon receipt of equipment:		
Removal and replacement of windspeed indicator	4-11	4-3	Checking unpacked equipment	2-2	2-1
Removal and replacement of wind vane tail assembly	4-12	4-3	Installing transmitter	2-4	2-3
Scope			Removing and replacing equip- ment in case	2-3	2-1
Tools, materials, and test equip- ment required	4-2	4-1	Siting.....	2-5	2-3
Transmitter circuit functions	4-14	4-4	Unpacking.....	2-1	2-1
Troubleshooting chart.....	4-10	4-3	Shipment and limited storage:		
Wind direction circuit functions	4-15	4-4	Disassembly of equipment	8-1	6-1
Packing equipment in carrying case	8-2	8-1	Packing of equipment in carry- ing case	8-2	8-1
			Siting	2-5	2-3
Preventive maintenance, operator: ...			Support, direct:		
Operator's preventive maintenance checks and service			Organizational of trouble- shooting procedures	5-3	5-1
periods	3-4	3-1	Removal and replacement of toggle switch	5-4	5-3
Operator's preventive maintenance checks and services			Removal and replacement of trigger switch assembly	5-5	5-3
chart	3-5	3-2	Scope	5-1	5-1
Preventive maintenance.....	3-3	3-1	Scope	5-1	5-1
Repair of replacement	3-8	3-2	Tools, materials, and test equip- ment required.....	5-2	5-1
Scope of operator's maintenance	3-1	3-1	Support, general		
Tools, materials, and test equip- ment required	3-2	3-1	Repair of windspeed trans- mitter	6-3	6-1
Preventive maintenance, organiza- tional:			Repair and adjustment of trigger switch assembly	6-4	6-1
Lubrication	4-5	4-1	Replacement of wind dial assembly.....	6-5	6-2
Monthly preventive maintenance	4-4	4-1	Scope	6-1	6-1
Monthly preventive maintenance checks and services chart	4-6	4-2	Tools, materials, and test equipment required.....	6-2	6-1
Quarterly preventive maintenance	4-7	4-2	Technical characteristics.....	1-5	1-2
Quarterly preventive maintenance checks and services	4-8	4-2	Tools, materials, and test equipment required:		
chart			Direct support	5-2	5-1

	Paragraph	Page		Paragraph	Page
Tools, materials, and test equipment required-Continued			Chart, organizational.....	4-10	4-3
Depot maintenance.....	7-2	7-1	General	4-9	4-3
General support	6-2	6-1	Organizational procedures....	5-3	5-1
Operator's maintenance..	3-2	3-1	Unpacking	2-1	2-1
Organizational maintenance	4-2	4-1	Wind dial assembly, replacement	6-5	6-2
Tropical climate operation	2-9	2-5	Windspeed indicator, removal and replacement.....	4-11	4-3
Troubleshooting:.....			Wind vane tail assembly, removal and replacement.....	4-12	4-3
Chart, operator's.....	3-7	3-2			

By Order of the Secretary of the Army:

WILLIAM C. WESTMORELAND,
General, United States Army,
Chief of Staff.

Official:

KENNETH G. WICKHAM,
Major General, United States Army,
The Adjutant General.

Distribution:

Active Army:

USASA (2)	Ft Gordon (10)
CNGB (1)	Ft Huachuca (10)
Dir/Trans (1)	Ft Carson (25)
CofEngrs (1)	Ft Knox (12)
TSG (1)	WSMR (5)
CofSptS (1)	Army Dep (2) except
ACSC-E (2)	LEAD (14)
USAARENBD (2)	SAAD (80)
USAIB (5)	TOAD (14)
USARADB (5)	LEAD (7)
USAAESWBD (5)	SHAD (3)
USAAVNTBD (5)	NAAD (5)
USACDC Agcy (1)	SVAD (5)
USAMC (5)	CHAD (3)
USCONARC (5)	ATAD (10)
ARADCOM (5)	ANAD (10)
ARADCOM Rgn (2)	TEAD (10)
OS Maj Comd (4)	FWAD (10)
LOGCOMD (2)	SIAD (10)
USAMICOM (4)	SXAD (10)
USASTRATCOM (4)	RRAD (10)
USAESC (70)	Gen Deps (2)
USARYIS (5)	Sig Sec Gen Deps (5)
MDW (1)	Sig Dep (12)
Armies (2)	Sig FLDMS (2)
Corps (2)	AMS (1)
USAC (3)	USAERDAA (2)
Svc Colleges (2)	USAERDAW (13)
USASCS (20)	USACRREL (2)
USAADS (2)	USABIOLABS (2)
USAAMS (2)	MAAG (2)
USAARMS (2)	USARMIS (2)
USAIS (2)	APG (5)
USAES (2)	Frankford Arsenal (5)
USASESS (20)	Units org under fol TOE: (2 copies each)
USAQMS (20)	1-55
USATC Armor (2)	1-66
USATC Inf (2)	1-59
USASTC (2)	1-75
WRAMC (1)	1-76
Army Pic Cen (2)	1-100
USACDCEC (10)	1-101
USATTC (5)	1-102
ARADMAC (5)	1-127
USATACOM (5)	1-128
Instl (2) except	1-137
Ft Hancock (4)	1-165

1-167	11-597
1-256	17
1-257	17-75
1-258	17-76
1-307	29-7
3-267	29-41
3-500	29-42
7	31-105
7-168	31-106
8-137	31-107
11-7	37
11-57	44-545
11-97	44-546
11-98	44-547
11-117	44-548
11-127	45-407
11-155	55-59
11-157	55-417
11-158	55-418
11-500 (AA-AC)	57
11-587	67
11-592	

NG: State AG (3)

USAR: None

For explanation of abbreviations used, see AR 320-50.

RECOMMENDED CHANGES TO EQUIPMENT TECHNICAL PUBLICATIONS



THEN... JOT DOWN THE DOPE ABOUT IT ON THIS FORM, CAREFULLY TEAR IT OUT, FOLD IT AND DROP IT IN THE MAIL!

SOMETHING WRONG WITH THIS PUBLICATION?

FROM: (PRINT YOUR UNIT'S COMPLETE ADDRESS)

DATE SENT

PUBLICATION NUMBER

PUBLICATION DATE

PUBLICATION TITLE

BE EXACT... PIN-POINT WHERE IT IS

PAGE NO.	PARA-GRAPH	FIGURE NO.	TABLE NO.

IN THIS SPACE TELL WHAT IS WRONG AND WHAT SHOULD BE DONE ABOUT IT:

TEAR ALONG PERFORATED LINE

PRINTED NAME, GRADE OR TITLE, AND TELEPHONE NUMBER

SIGN HERE:

DA FORM 2028-2
1 JUL 79

PREVIOUS EDITIONS ARE OBSOLETE.

P.S.—IF YOUR OUTFIT WANTS TO KNOW ABOUT YOUR RECOMMENDATION MAKE A CARBON COPY OF THIS AND GIVE IT TO YOUR HEADQUARTERS.

THE METRIC SYSTEM AND EQUIVALENTS

WEIGHT MEASURE

1 Centimeter = 10 Millimeters = 0.01 Meters = 0.3937 Inches
 1 Meter = 100 Centimeters = 1000 Millimeters = 39.37 Inches
 1 Kilometer = 1000 Meters = 0.621 Miles

WEIGHTS

1 Gram = 0.001 Kilograms = 1000 Milligrams = 0.035 Ounces
 1 Kilogram = 1000 Grams = 2.2 lb.
 1 Metric Ton = 1000 Kilograms = 1 Megagram = 1.1 Short Tons

LIQUID MEASURE

1 Milliliter = 0.001 Liters = 0.0338 Fluid Ounces
 1 Liter = 1000 Milliliters = 33.82 Fluid Ounces

SQUARE MEASURE

1 Sq. Centimeter = 100 Sq. Millimeters = 0.155 Sq. Inches
 1 Sq. Meter = 10,000 Sq. Centimeters = 10.76 Sq. Feet
 1 Sq. Kilometer = 1,000,000 Sq. Meters = 0.386 Sq. Miles

CUBIC MEASURE

1 Cu. Centimeter = 1000 Cu. Millimeters = 0.06 Cu. Inches
 1 Cu. Meter = 1,000,000 Cu. Centimeters = 35.31 Cu. Feet

TEMPERATURE

$5/9(^{\circ}\text{F} - 32) = ^{\circ}\text{C}$
 212° Fahrenheit is equivalent to 100° Celsius
 90° Fahrenheit is equivalent to 32.2° Celsius
 32° Fahrenheit is equivalent to 0° Celsius
 $9/5^{\circ}\text{C} + 32 = ^{\circ}\text{F}$

APPROXIMATE CONVERSION FACTORS

TO CHANGE	TO	MULTIPLY BY
Inches	Centimeters	2.540
Feet	Meters	0.305
Yards	Meters	0.914
Miles	Kilometers	1.609
Square Inches	Square Centimeters	6.451
Square Feet	Square Meters	0.093
Square Yards	Square Meters	0.836
Square Miles	Square Kilometers	2.590
Acres	Square Hectometers	0.405
Cubic Feet	Cubic Meters	0.028
Cubic Yards	Cubic Meters	0.765
Fluid Ounces	Milliliters	29.573
its	Liters	0.473
arts	Liters	0.946
allons	Liters	3.785
Ounces	Grams	28.349
Pounds	Kilograms	0.454
Short Tons	Metric Tons	0.907
Pound-Feet	Newton-Meters	1.356
Pounds per Square Inch	Kilopascals	6.895
Miles per Gallon	Kilometers per Liter	0.425
Miles per Hour	Kilometers per Hour	1.609

TO CHANGE	TO	MULTIPLY BY
Centimeters	Inches	0.394
Meters	Feet	3.280
Meters	Yards	1.094
Kilometers	Miles	0.621
Square Centimeters	Square Inches	0.155
Square Meters	Square Feet	10.764
Square Meters	Square Yards	1.196
Square Kilometers	Square Miles	0.386
Square Hectometers	Acres	2.471
Cubic Meters	Cubic Feet	35.315
Cubic Meters	Cubic Yards	1.308
Milliliters	Fluid Ounces	0.034
Liters	Pints	2.113
Liters	Quarts	1.057
ers	Gallons	0.264
ms	Ounces	0.035
ograms	Pounds	2.205
Metric Tons	Short Tons	1.102
Newton-Meters	Pounds-Feet	0.738
Kilopascals	Pounds per Square Inch	0.145
ometers per Liter	Miles per Gallon	2.354
ometers per Hour	Miles per Hour	0.621

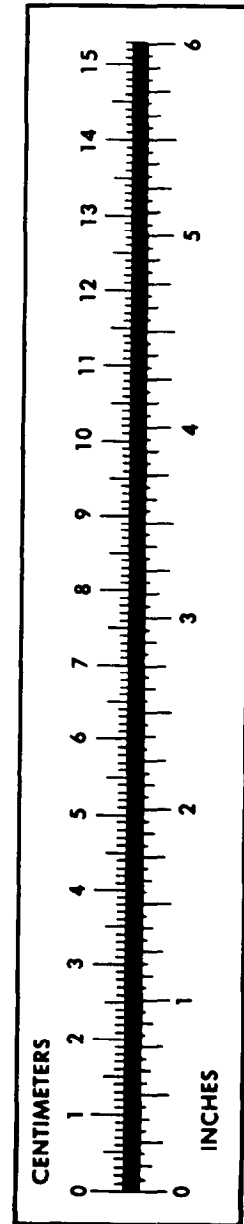

PIN: 019479-003